

# Technical Data

## 4000 Series

# 4012-46TWG2A

# 4012-46TWG3A

Diesel Engine - ElectropaK

1500 rev/min

### Basic technical data

Number of cylinders .....	12
Cylinder arrangement .....	Vee 60°
Cycle .....	4 stroke, compression ignition
Induction system .....	turbocharged
Combustion system.....	direct injection
Compression ratio .....	13:1 nominal
Bore.....	160 mm
Stroke .....	190 mm
Cubic capacity.....	45.842 litres
Direction of rotation .....	Anti clockwise viewed on flywheel
Firing order .....	1 <sup>A</sup> ,6 <sup>B</sup> ,5 <sup>A</sup> ,2 <sup>B</sup> ,3 <sup>A</sup> ,4 <sup>B</sup> ,6 <sup>A</sup> ,1 <sup>B</sup> ,2 <sup>A</sup> ,5 <sup>B</sup> ,4 <sup>A</sup> ,3 <sup>B</sup>
Cylinder 1 .....	furthest from flywheel

**Note:** Cylinders designated 'A' are on the right hand side of the engine when viewed from the flywheel end.

### Total weight of ElectropaK

Engine - dry	
-temperate .....	4440 kg
-tropical .....	4440 kg
ElectropaK - dry <sup>(1)</sup>	
-temperate .....	5220 kg
-tropical .....	5283 kg
ElectropaK - wet <sup>(1) (2)</sup>	
-temperate .....	5547 kg
-tropical .....	5615 kg

1. Includes fuel cooler.

2. Includes engine lubricating oil and water jacket

### Overall dimensions of ElectropaK

Height .....	2255 mm
Length .....	3714 mm
Width	
-temperate .....	1780 mm
-tropical .....	1978 mm

### Moment of inertia (mk<sup>2</sup>)

Flywheel .....	9,57 kgm <sup>2</sup>
Engine.....	9,73 kgm <sup>2</sup>

### Cyclic irregularity

For engine/flywheel maximum:

-4012-46TWG2A @ 1500 rev/min.....	1-752
-4012-46TWG3A @ 1500 rev/min.....	1-752

### Ratings

Steady state speed stability at constant load .....

± 0,25%

Electrical ratings are based on average alternator efficiency and are for guidance only (0.8 power factor being used).

### Operating point

Engine speed .....	1500 rev/min
Static injection timing .....	spill timing 22°
Cooling water exit temperature .....	< 98 °C

### Performance

**Note:** All data based on operation to ISO 3046/1, BS 5514 and DIN 6271 standard reference conditions.

Estimated sound pressure level at 1 metre .....

111 d(B)A

**Note:** Noise levels represent highest recorded at 1500 rev/min

For engines operating in ambient conditions other than the standard reference conditions stated below, a suitable de-rate must be applied.

De-rate tables for increased ambient temperatures and / or altitude are available, please contact Perkins Applications Department

### Test conditions

-air temperature.....	25 °C
-barometric pressure .....	100 kPa
-relative humidity .....	30%
-air inlet restriction at maximum power (nominal).....	2,5 kPa
-exhaust back pressure at maximum power (nominal).....	3,0 kPa
-maximum fuel temperature (inlet pump) .....	58 °C

For test conditions relevant to data on load acceptance, please refer to Cold start recommendations on page 22 of this document.

**General installation - 4012-46TWG2A (Temperate) 50 Hz @ 1500 rev/min**

Designation	Units	Type of operation and application		
		Base	Prime	Standby
Gross engine power	kWb	884	1106	1217
Fan and battery charging alternator power	kW	51		
Net engine power	kWm	833	1055	1166
Brake mean effective pressure (gross)	kPa	1543	1930	21,24
Combustion air flow at ISO conditions	m³/min	90	102	109
Exhaust gas temperature (max) after turbo	°C	422		
Exhaust gas flow (max) at atmospheric pressure	m³/min	230		
Boost pressure ratio	-	2,38	2,86	3,09
Mechanical efficiency	%	88.0	90.2	91.0
Overall thermal efficiency (nett)	%	39.46	39.81	39.66
Friction and pumping power losses	kWm	120		
Mean piston speed	m/s	9,5		
Engine coolant flow	l/min	948		
Typical GenSet electrical output (0.8pf)	kVA	989	1253	1385
	kWe	791	1002	1108
Assumed alternator efficiency	%	95		

**General installation - 4012-46TWG2A (Tropical) 50 Hz @ 1500 rev/min**

Designation	Units	Type of operation and application		
		Base	Prime	Standby
Gross engine power	kWb	891	1113	1224
Fan and battery charging alternator power	kW	58		
Net engine power	kWm	833	1055	1166
Brake mean effective pressure (gross)	kPa	1555	1942	2136
Combustion air flow at ISO conditions	m³/min	90	103	109
Exhaust gas temperature (max) after turbo	°C	422		
Exhaust gas flow (max) at atmospheric pressure	m³/min	235		
Boost pressure ratio	-	2,39	2,87	3,10
Mechanical efficiency	%	88.1	90.3	91.1
Overall thermal efficiency (nett)	%	39,5	39,8	39,6
Friction and pumping power losses	kWm	120		
Mean piston speed	m/s	9,5		
Engine coolant flow	l/min	948		
Typical GenSet electrical output (0.8pf)	kVA	989	1253	1385
	kWe	791	1002	1108
Assumed alternator efficiency	%	95		

**Notes:**

- All quoted gross engine powers include an allowance of 1.5% for installation variance
- Not to be used for CHP design purposes (indicative figures only). Consult Perkins Engines Stafford Limited. Assumes complete combustion.

### General installation - 4012-46TWG3A (Temperate), 50 Hz @ 1500 rev/min

Designation	Units	Type of operation and application		
		Base	Prime	Standby
Gross engine power	kWb	960	1200	1314
Fan and battery charging alternator power	kW	51		
Net engine power	kWm	909	1149	1263
Brake mean effective pressure (gross)	kPa	1675	2094	2293
Combustion air flow at ISO conditions	m <sup>3</sup> /min	94	108	114
Exhaust gas temperature (max) after turbo	°C	474		
Exhaust gas flow (max) at atmospheric pressure	m <sup>3</sup> /min	240		
Boost pressure ratio	-	2.55	3.05	3.28
Mechanical efficiency	%	88.9	90.9	91.6
Overall thermal efficiency (nett)	%	39.66	39.80	38.95
Friction and pumping power losses	kWm	120		
Mean piston speed	m/s	9,5		
Engine coolant flow	l/min	948		
Typical GenSet electrical output (0.8pf)	kVA	1079	1364	1500
	kWe	864	1092	1200
Assumed alternator efficiency	%	95		

### General installation - 4012-46TWG3A (Tropical), 50 Hz @ 1500 rev/min

Designation	Units	Type of operation and application		
		Base	Prime	Standby
Gross engine power	kWb	967	1207	1321
Fan and battery charging alternator power	kW	58		
Net engine power	kWm	909	1149	1263
Brake mean effective pressure (gross)	kPa	1688	2106	2305
Combustion air flow at ISO conditions	m <sup>3</sup> /min	94	108	115
Exhaust gas temperature (max) after turbo	°C	479		
Exhaust gas flow (max) at atmospheric pressure	m <sup>3</sup> /min	245		
Boost pressure ratio	-	2.56	3.07	3.30
Mechanical efficiency	%	89.0	91.0	91.7
Overall thermal efficiency (nett)	%	39.67	39.75	38.92
Friction and pumping power losses	kWm	120		
Mean piston speed	m/s	9,5		
Engine coolant flow	l/min	948		
Typical GenSet electrical output (0.8pf)	kVA	1079	1364	1500
	kWe	864	1092	1200
Assumed alternator efficiency	%	95		

#### Notes:

- All quoted gross engine powers include an allowance of 1.5% for installation variance
- Not to be used for CHP design purposes (indicative figures only). Consult Perkins Engines Stafford Limited. Assumes complete combustion.

## Rating definitions

### Baseload power

Unlimited hours usage with an average load factor of 100% of the published baseload power rating.

### Prime Power

Variable load. Unlimited hours usage with an average load factor of 80% of the published prime power rating over each 24 hr. period A 10% overload is available for 1 hour in every 12 hour of operation.

### Standby power

Variable load. Limited to 500 hours annual usage up to 300 hours of which may be continuous running. No overload is permitted.

### Emissions capability

All 4012-46TWG ratings are optimised to the 'best fuel consumption' and do not comply to Harmonised International Regulation Emission Limits. More information on these statements can be obtained by contacting the Applications Department at Perkins Engines Company Limited.

## Energy balance

### 4012-46TWG2A - Temperate

Designation	Units	50 Hz @ 1500 rev/min		
		Baseload power	Prime power	Standby power
Energy in fuel	kWt	2107	2632	2939
Energy in power output (gross)	kWb	884	1106	1217
Energy to cooling fan	kWm	51		
Energy in power output (nett)	kWm	833	1055	1166
Energy to exhaust	kWt	684	878	1001
Energy to coolant and oil	kWt	345	372	401
Energy to radiation	kWt	64	81	89
Energy to charge cooler	kWt	131	195	232

### 4012-46TWG2A - Tropical

Designation	Units	50 Hz @ 1500 rev/min		
		Baseload power	Prime power	Standby power
Energy in fuel	kWt	2123	2650	2960
Energy in power output (gross)	kWb	891	1113	1224
Energy to cooling fan	kWm	58		
Energy in power output (nett)	kWm	833	1055	1166
Energy to exhaust	kWt	689	886	1009
Energy to coolant and oil	kWt	345	374	403
Energy to radiation	kWt	65	81	89
Energy to charge cooler	kWt	133	197	234

### 4012-46TWG3A - Temperate

Designation	Units	50 Hz @ 1500 rev/min		
		Baseload power	Prime power	Standby power
Energy in fuel	kWt	2278	2889	3245
Energy in power output (gross)	kWb	960	1200	1314
Energy to cooling fan	kWm	51		
Energy in power output (nett)	kWm	909	1149	1263
Energy to exhaust	kWt	745	981	1128
Energy to coolant and oil	kWt	352	395	441
Energy to radiation	kWt	70	87	96
Energy to charge cooler	kWt	151	226	266

### 4012-46TWG3A - Tropical

Designation	Units	50 Hz @ 1500 rev/min		
		Baseload power	Prime power	Standby power
Energy in fuel	kWt	2294	2910	3269
Energy in power output (gross)	kWb	967	1207	1321
Energy to cooling fan	kWm	58		
Energy in power output (nett)	kWm	909	1149	1263
Energy to exhaust	kWt	751	989	1138
Energy to coolant and oil	kWt	353	398	445
Energy to radiation	kWt	70	88	96
Energy to charge cooler	kWt	153	228	269

**Note:** Not to be used for combined heat and power (CHP) purposes (indicative figures only), if required, please consult Perkins Engines Company Limited.

## Exhaust system

Outlet size (internal) ... 2 x 254 mm  
 Outlet flange size ... 10" table D  
 Back pressure for total system ... 5 kPa  
 For recommended pipe sizes, refer to the Installation Manual.

## Induction system

Emissions data with combustion air temperature of 25 °C

Maximum air intake restriction of engine:

-clean filter ... 2 kPa  
 -dirty filter ... 4 kPa  
 -air filter type ... heavy duty axial flow

4012-46TWG2A Temperate - left view

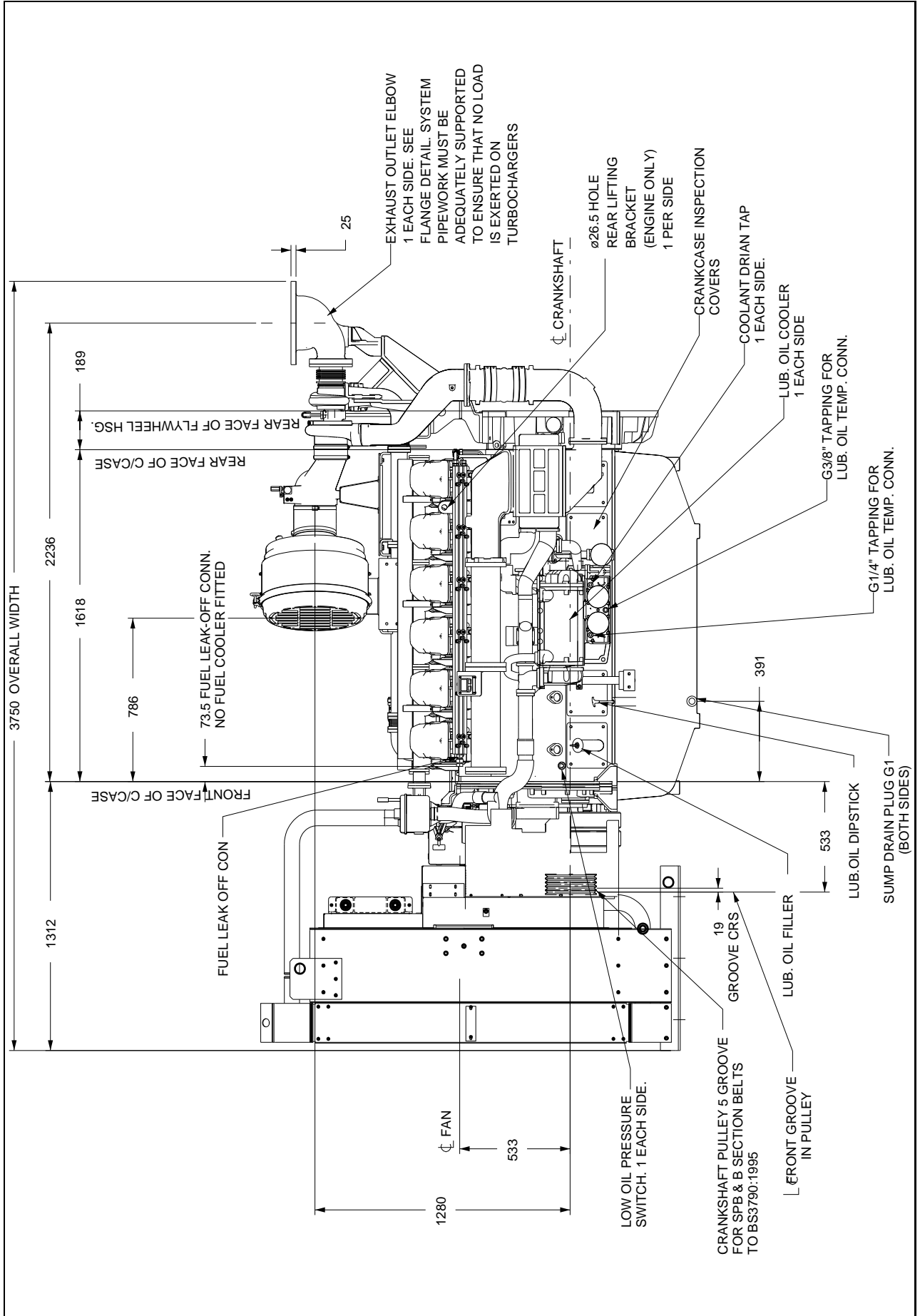

**4012-46TWG2A Temperate - front view**

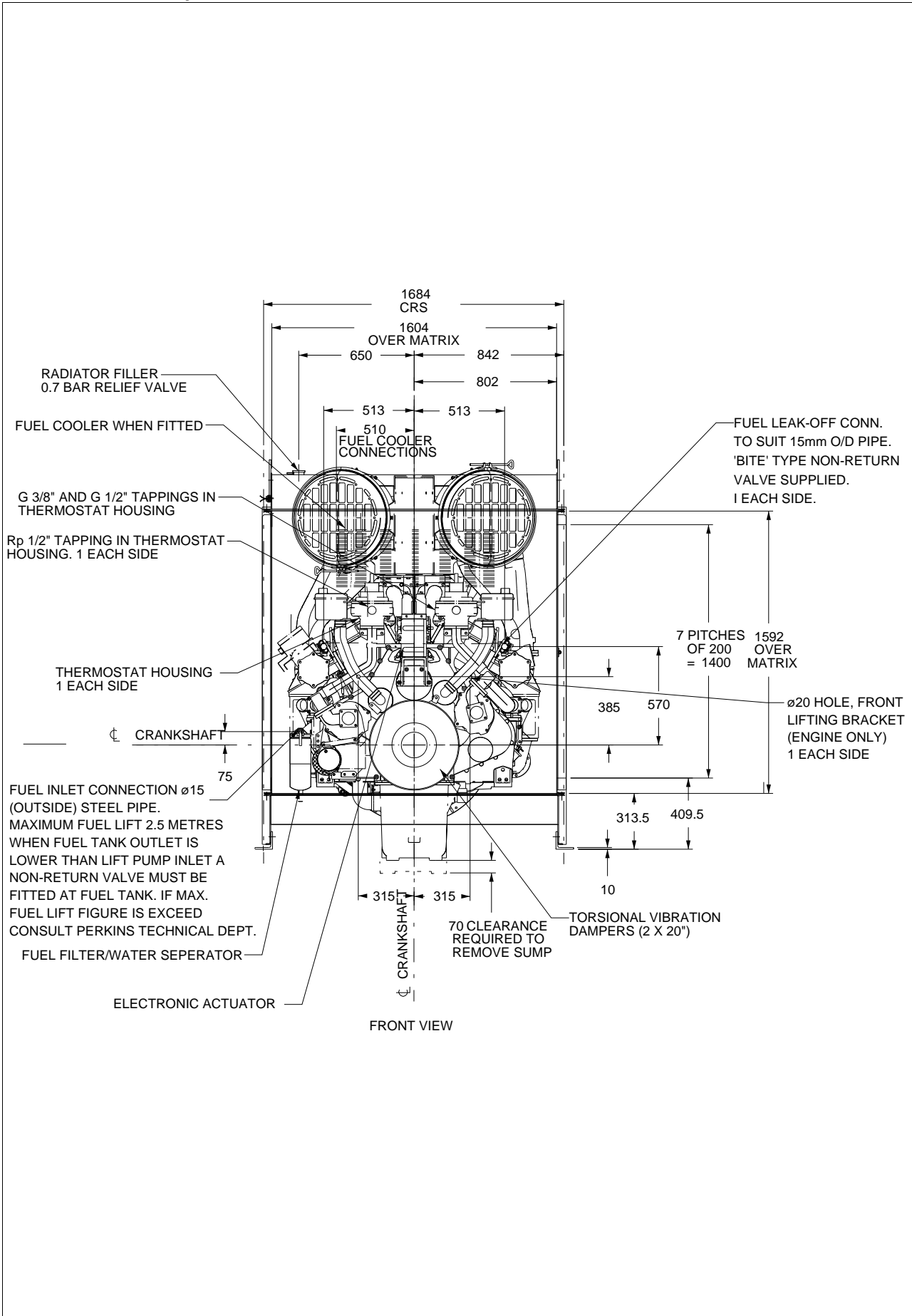

4012-46TWG2A Temperate - right view

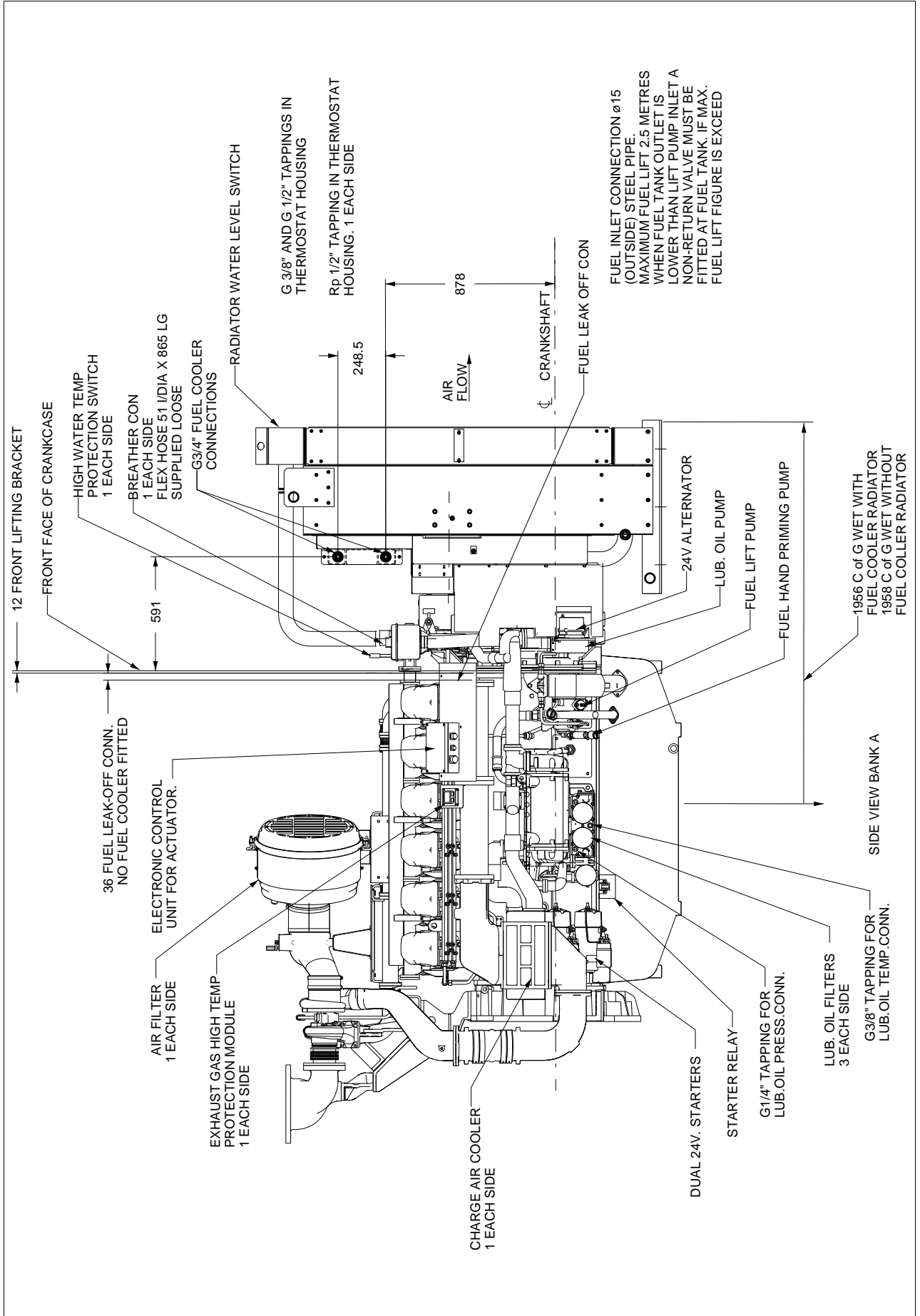

**4012-46TWG2A Temperate - rear view**

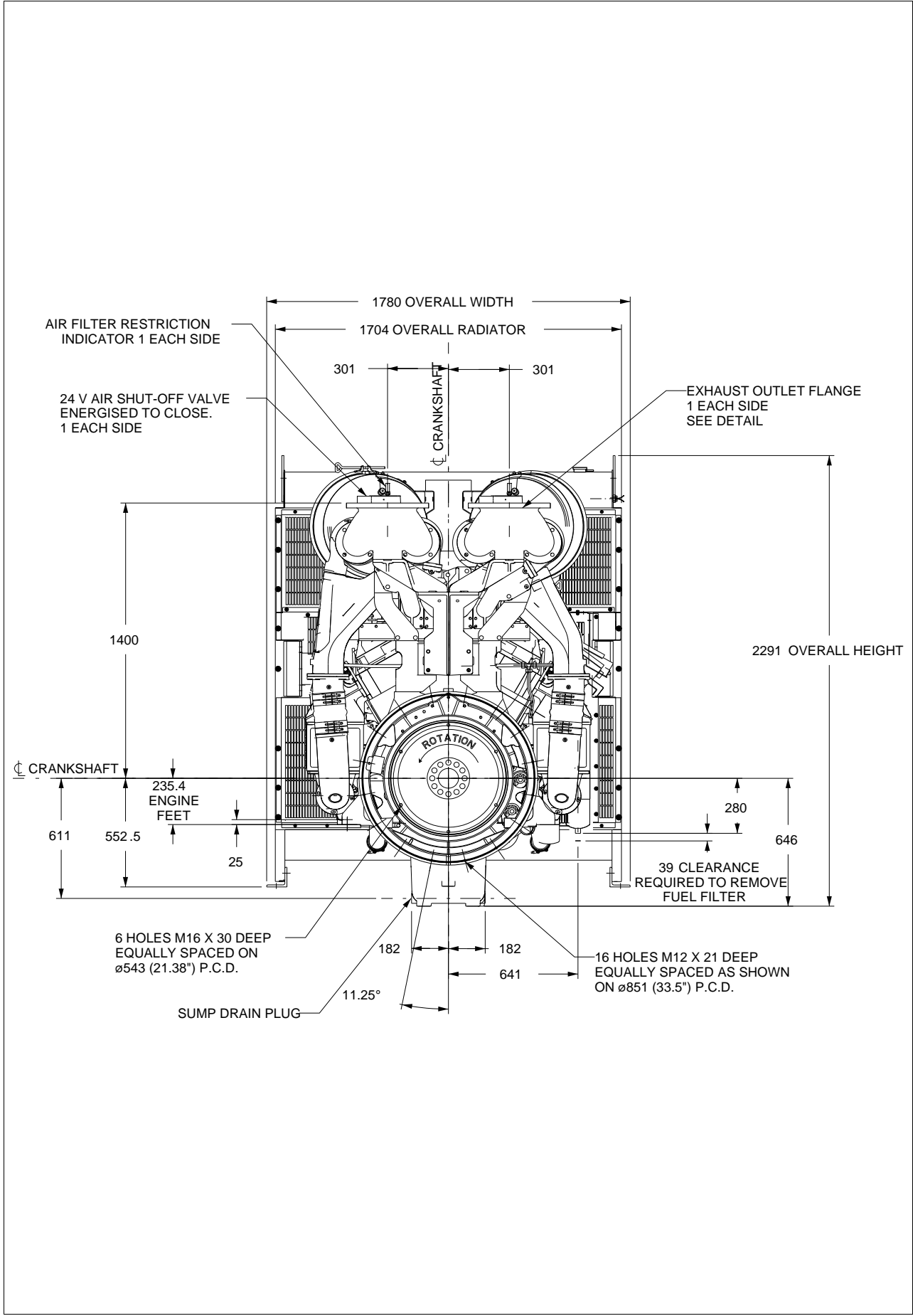



4012-46TWG2A Temperate - Support pads, exhaust outlet flange and flywheel detail

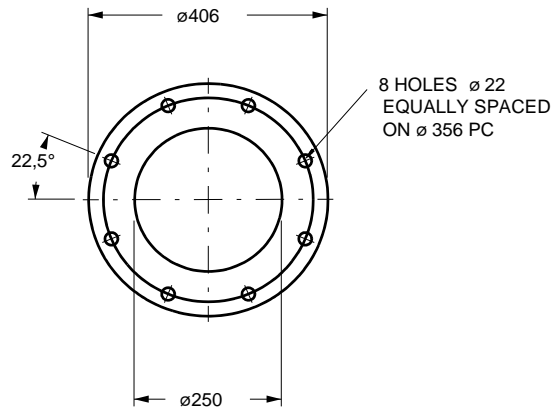

DETAIL OF EXHAUST OUTLET FLANGE  
(B.S.10 TABLE D)  
SCALE 1:5

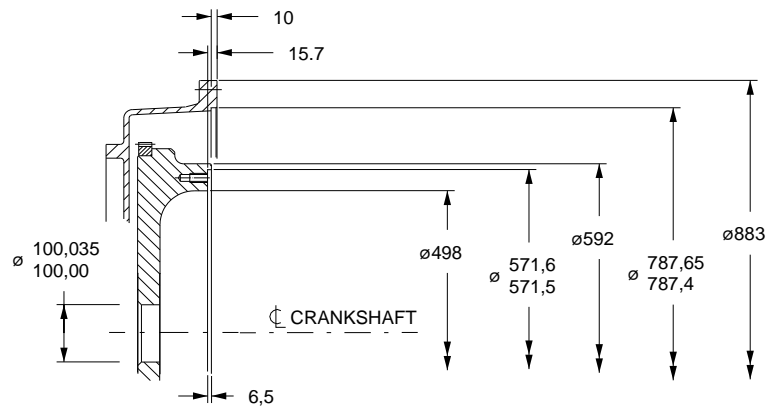

DETAIL OF SAE 518 FLYWHEEL  
AND SAE 00 FLYWHEEL HOUSING  
(METRIC TAPPINGS)  
SCALE 1:5

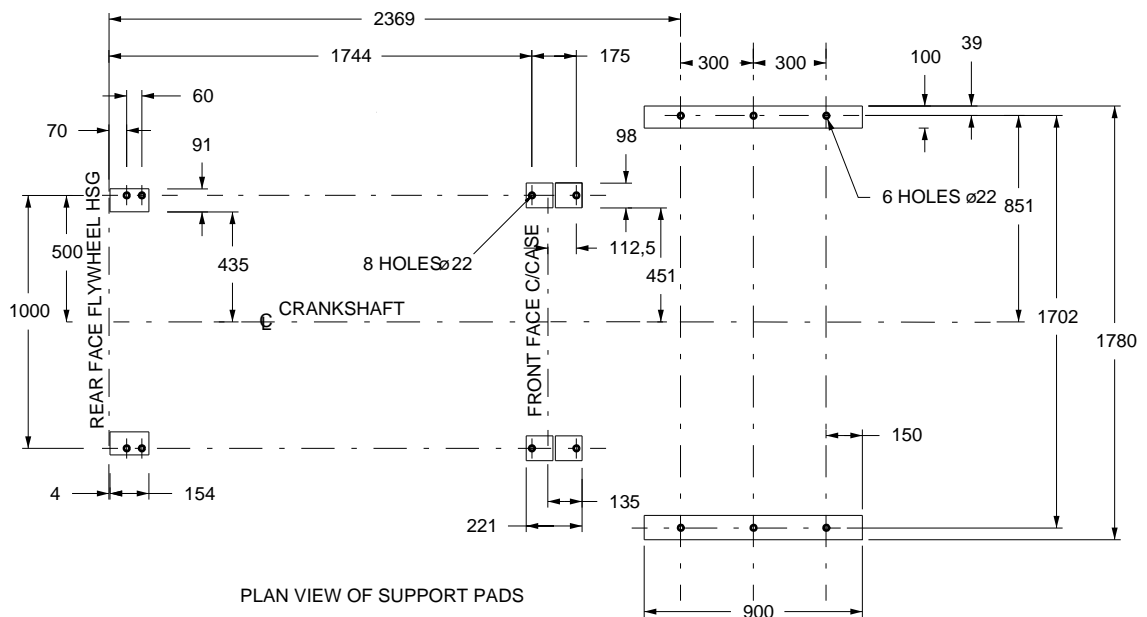

4012-46TWG2A Tropical - 4012-46TWG3A Temperate - left view

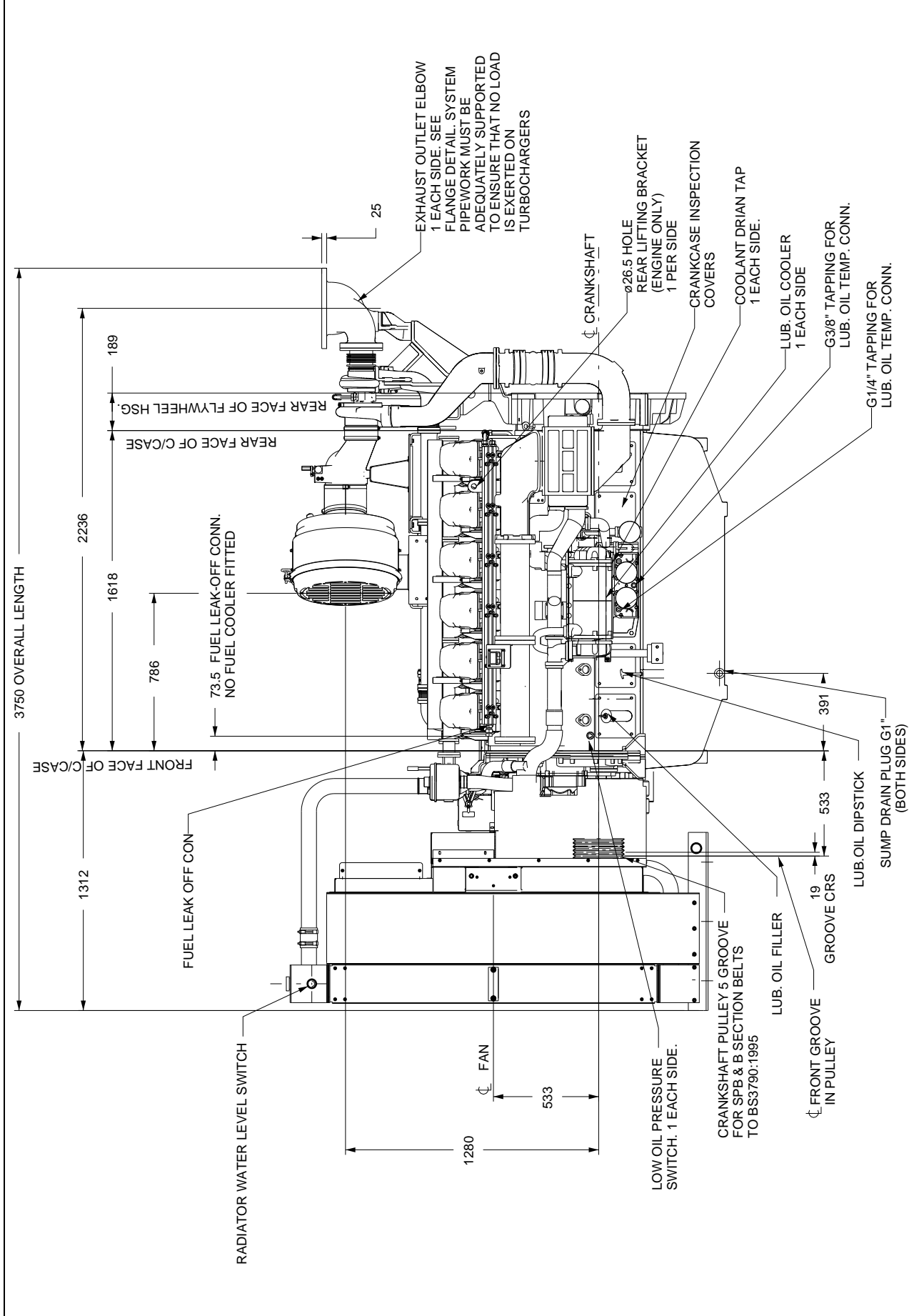

4012-46TWG2A Tropical - 4012-46TWG3A Temperate - front view

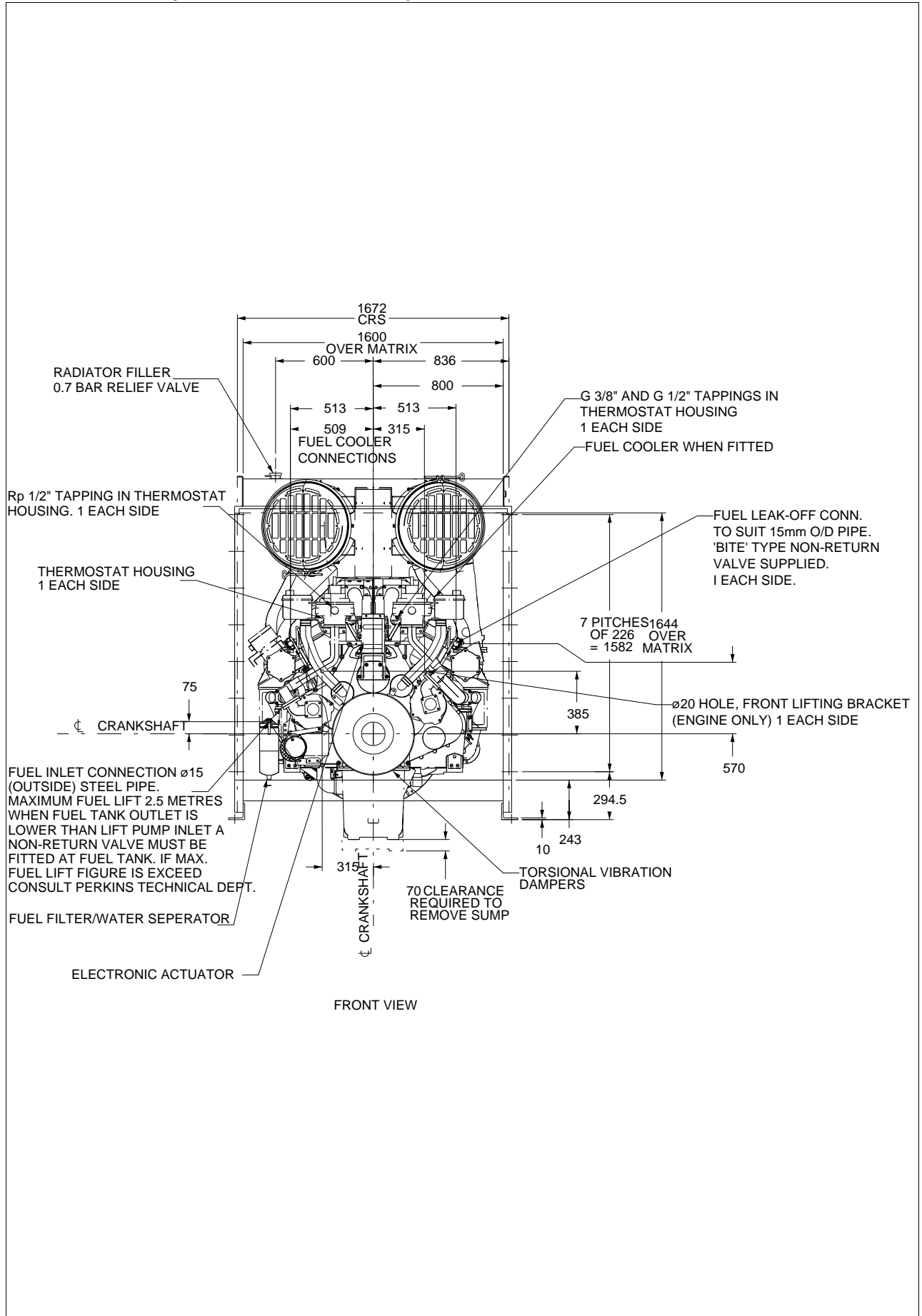

4012-46TWG2A Tropical - 4012-46TWG3A Temperate - right view

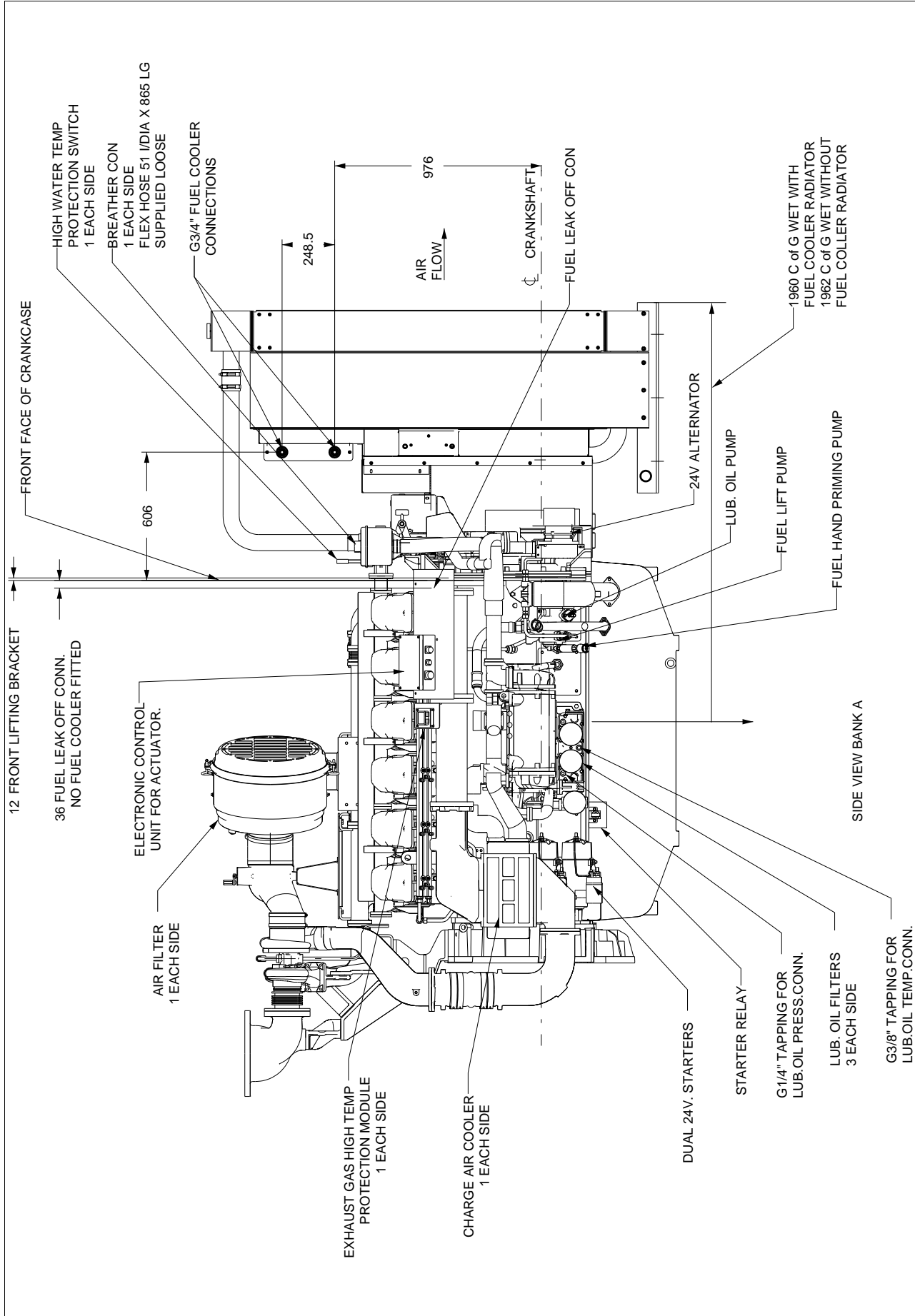

4012-46TWG2A Tropical - 4012-46TWG3A Temperate- rear view

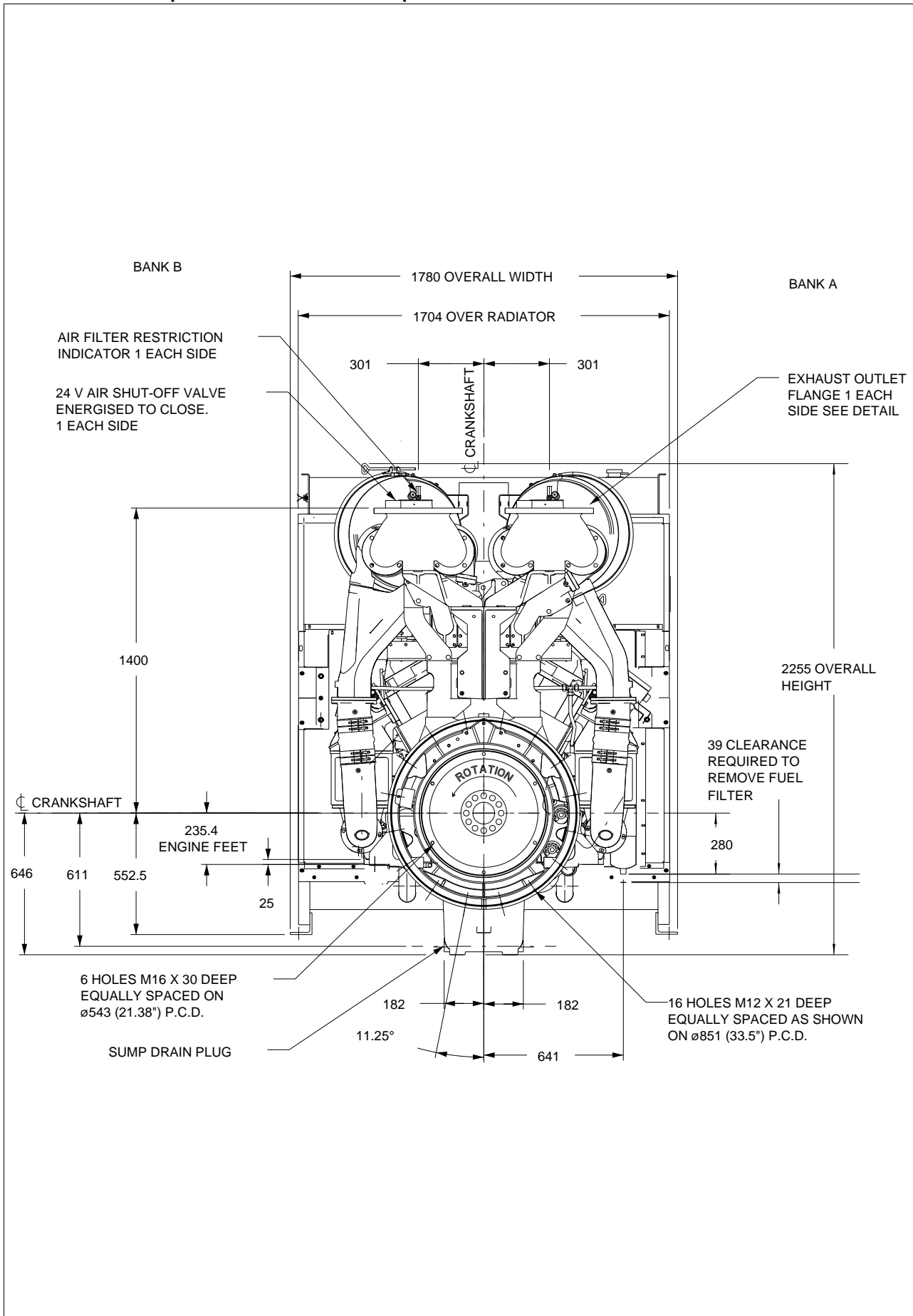

**4012-46TWG2A Tropical - 4012-46TWG3A Temperate - Support pads, exhaust outlet flange and flywheel detail**

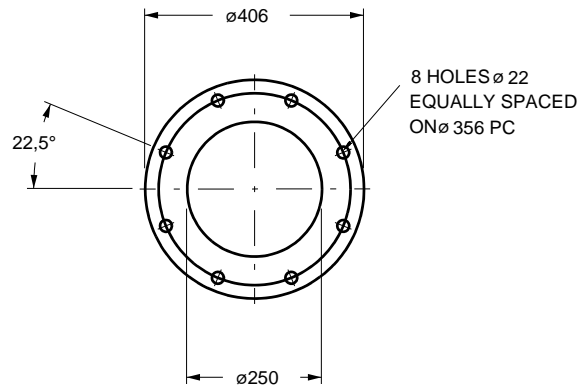

DETAIL OF EXHAUST OUTLET FLANGE  
(B.S.10 TABLE D)  
SCALE 1:5

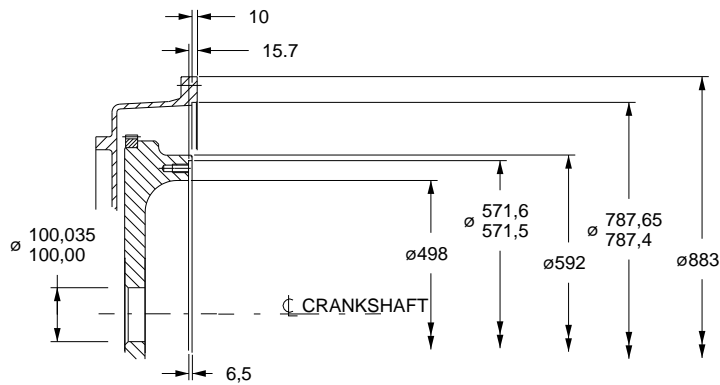

DETAIL OF SAE 518 FLYWHEEL  
AND SAE 00 FLYWHEEL HOUSING  
(METRIC TAPPINGS)  
SCALE 1:5

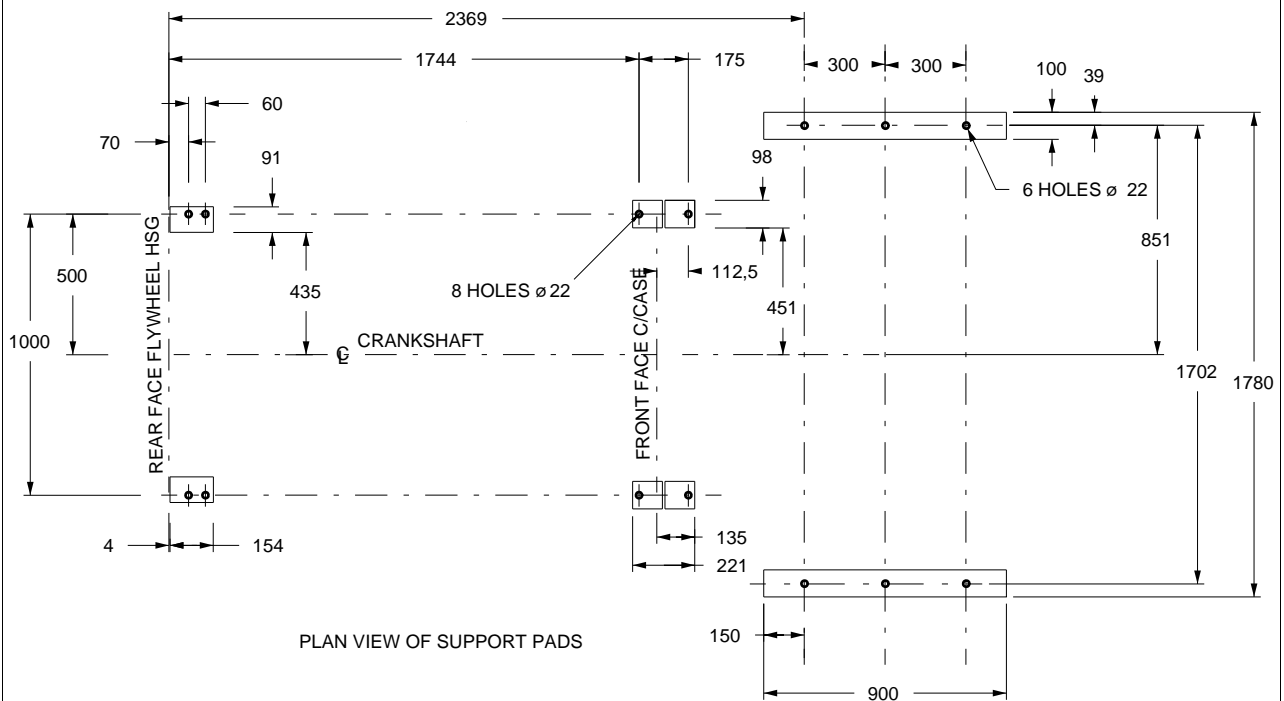

4012-46TWG3A Tropical - left view

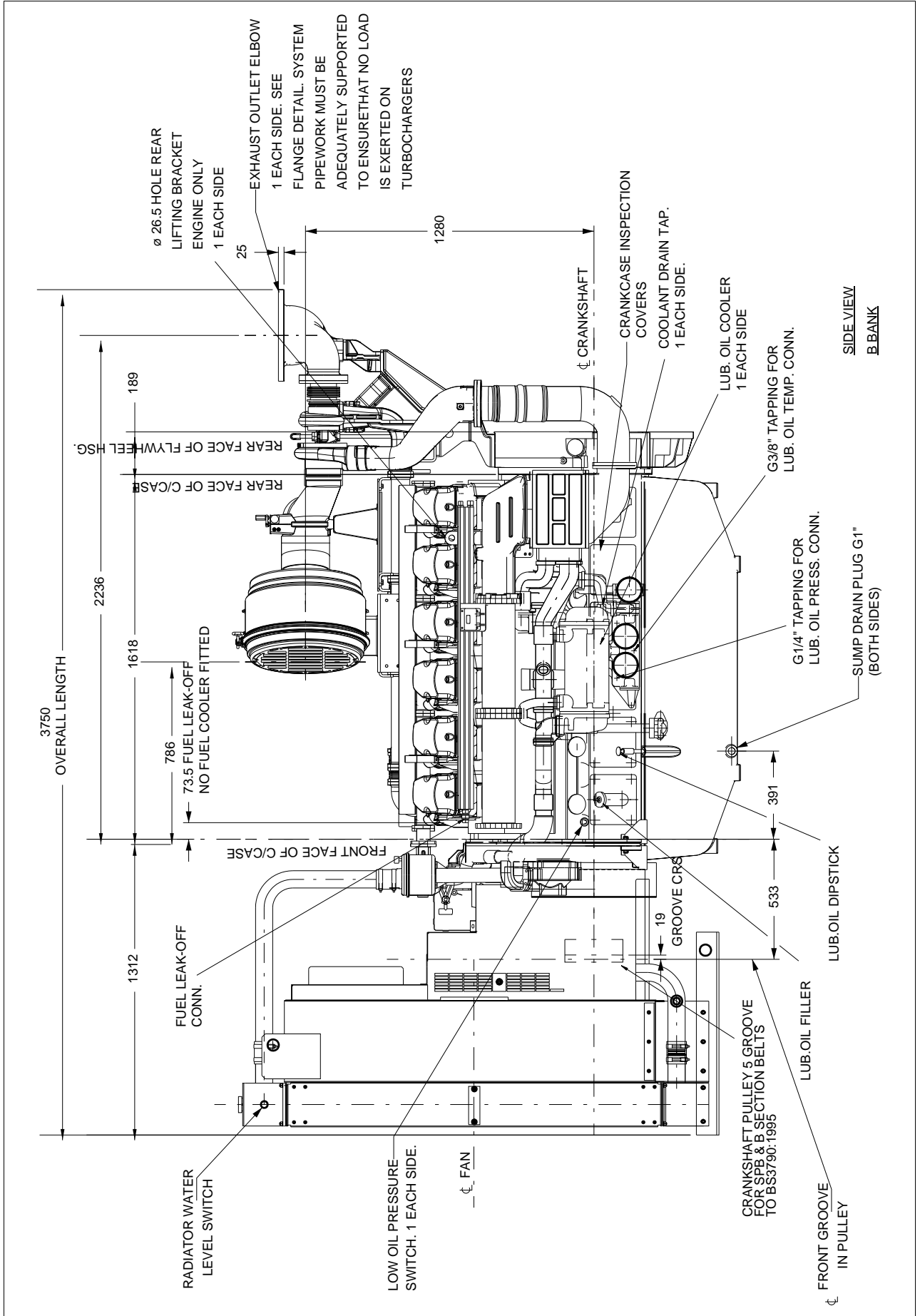

4012-46TWG3A Tropical - front view

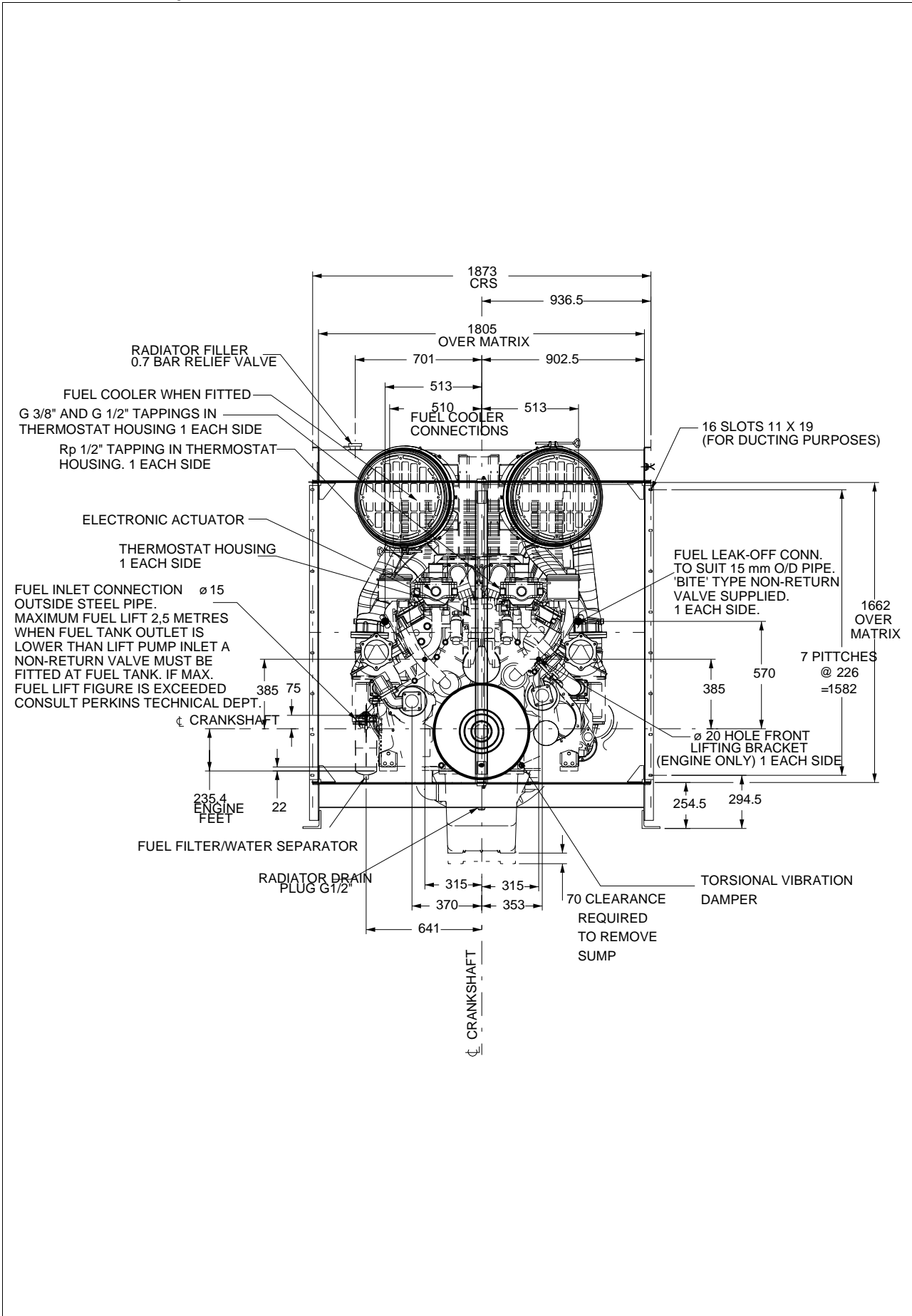



4012-46TWG3A Tropical - right view

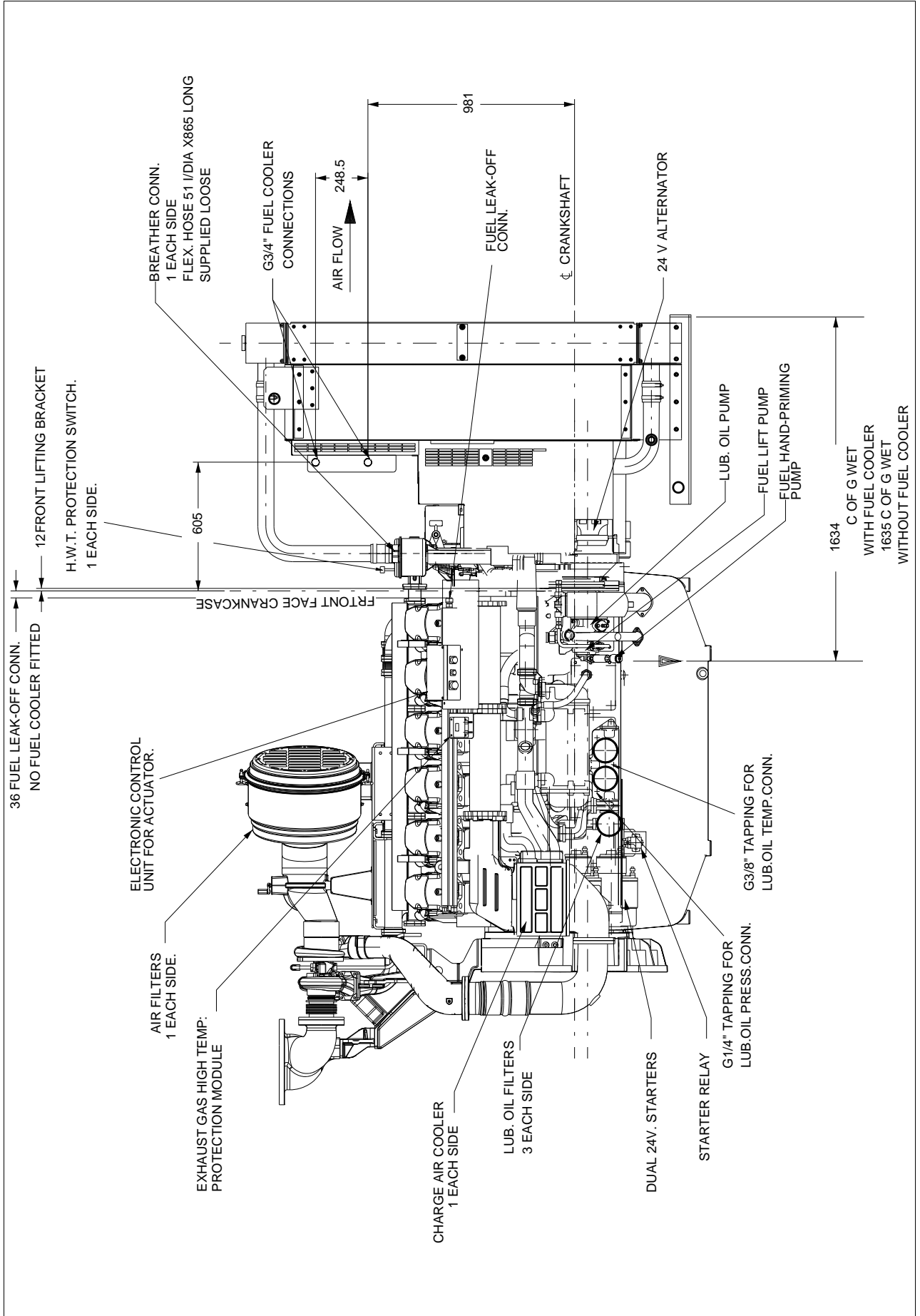

**4012-46TWG3A Tropical - rear view**

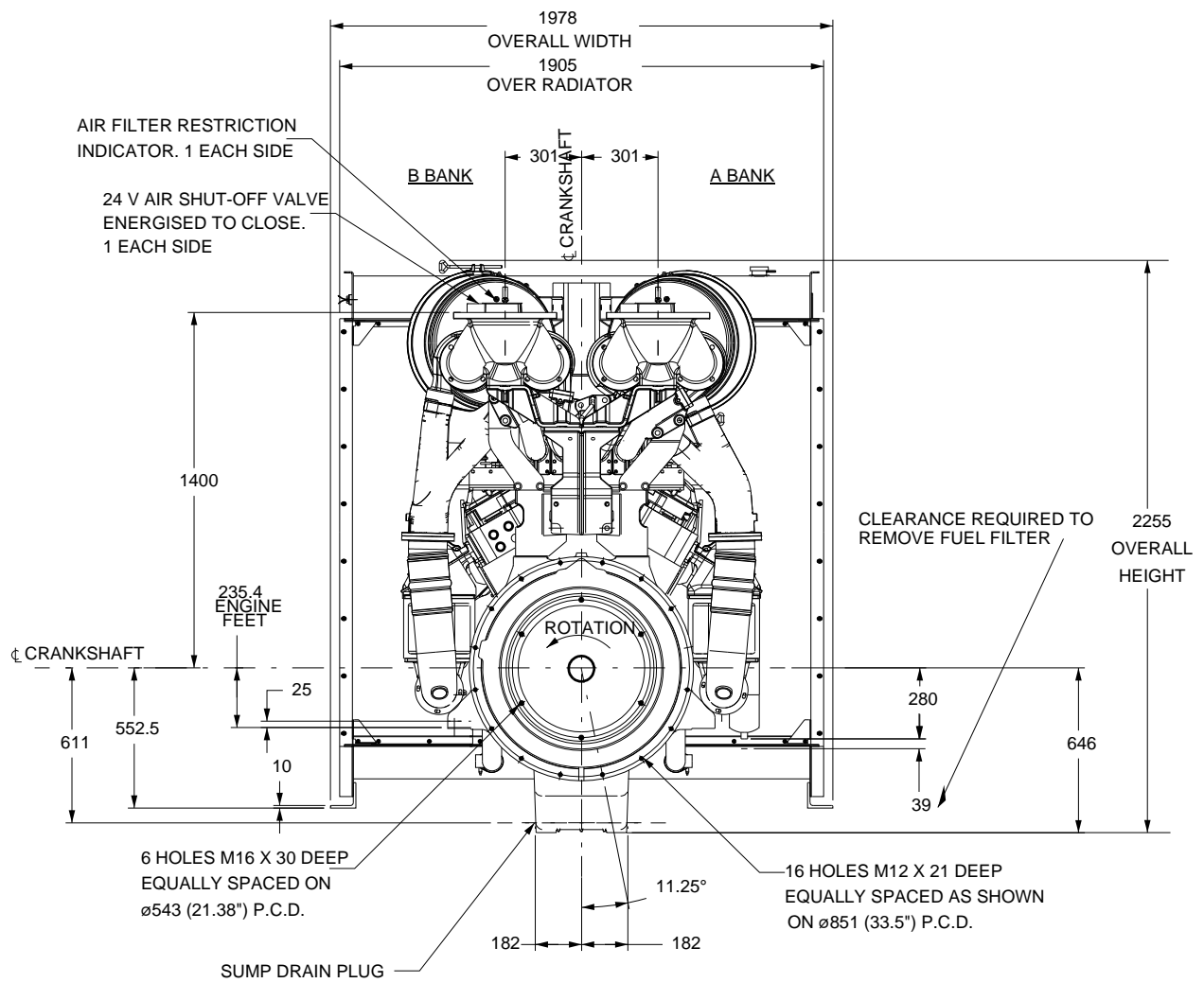

### 4012-46TWG3A Tropical - Support pads, exhaust outlet flange and flywheel details

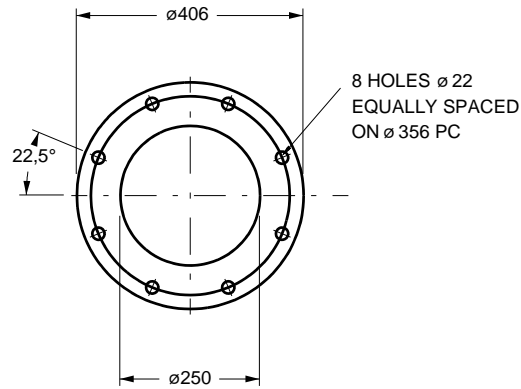

DETAIL OF EXHAUST OUTLET FLANGE  
(B.S.10 TABLE D)  
SCALE 1:5

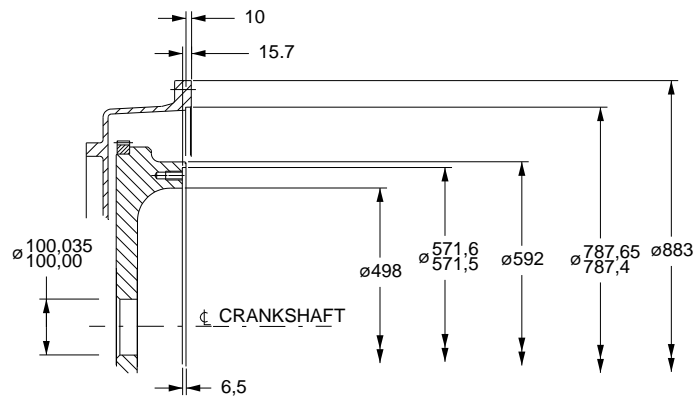

DETAIL OF SAE 518 FLYWHEEL  
AND SAE 00 FLYWHEEL HOUSING  
(METRIC TAPPINGS)  
SCALE 1:5

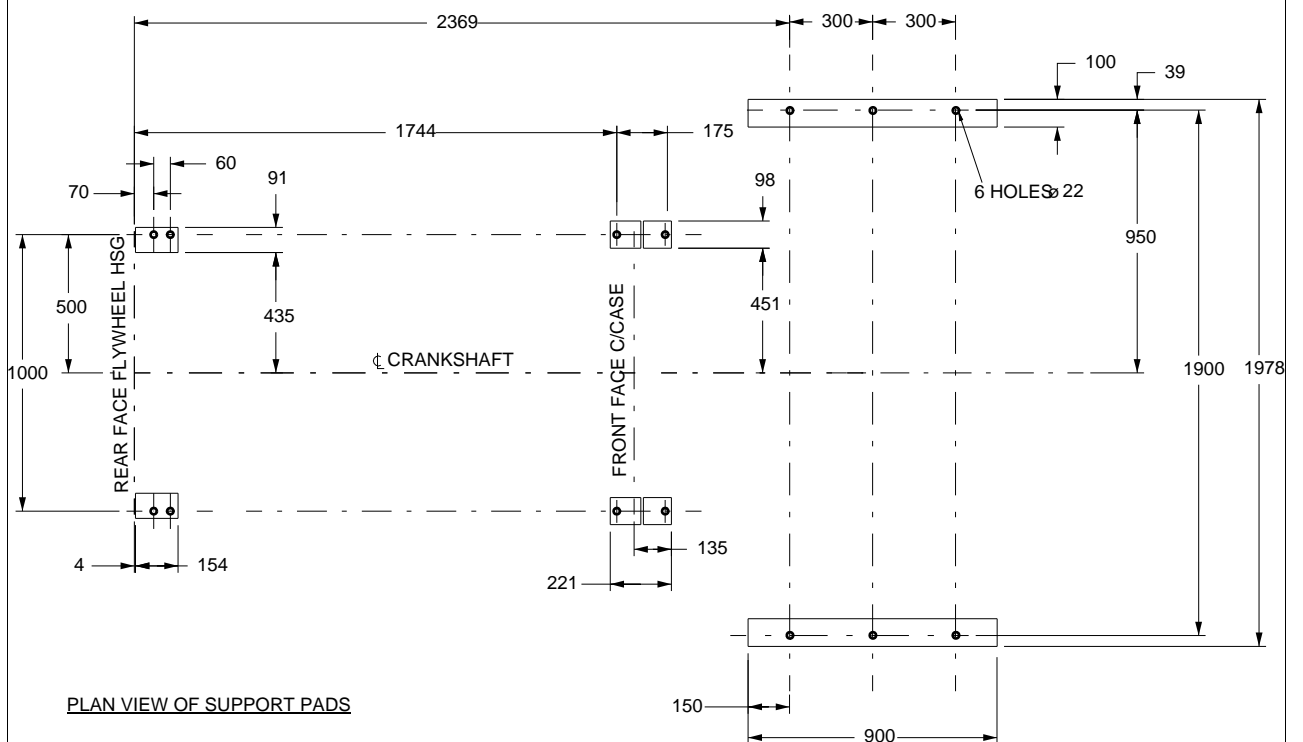

## Cooling system

Recommended coolant: 50% inhibited ethylene glycol or 50% inhibited propylene glycol and 50% clean fresh water. For CHP systems and where there is no likelihood of ambient temperature below 10 °C, then clean 'soft' water may be used, treated with 1% by volume of Perkins inhibitor in the cooling system. The inhibitor is available in 1 litre bottles from all Perkins Distributors.

Maximum pressure in crankcase water jacket . . . . . 170 kPa  
 Maximum top tank temperature (standby) . . . . . 98 °C  
 Maximum static pressure on pump . . . . . 70 kPa  
 Maximum pressure cap setting . . . . . 70 kPa

### Total coolant capacity

Electronit (engine only) . . . . . 73 litres  
 ElectropaK  
 -temperate (engine and radiator) . . . . . 196 litres  
 -tropical (engine and radiator) . . . . . 201 litres  
 Maximum permissible restriction to coolant pump flow . . . . . 20 kPa  
 Thermostat operating range . . . . . 71 - 85 °C  
 Temperature rise across the engine (standby power) with inhibited coolant . . . . . 8 °C  
 Shutdown switch setting . . . . . 101 °C (rising)  
 Coolant immersion heater capacity . . . . . 2 x 4 kW

### Water jacket cooling data

Coolant flow . . . . . 948 l/min  
 Coolant exit temperature (max) . . . . . 98 °C  
 Coolant inlet temperature (min) . . . . . 70 °C  
 Coolant inlet temperature (max) . . . . . 85 °C

## Coolant pump

-speed . . . . . 1.4 x engine rev/min  
 -method of drive . . . . . engine (gear) driven

### Radiator

Face area  
 -temperate . . . . . 2630400 mm<sup>2</sup>  
 -tropical . . . . . 2967420 mm<sup>2</sup>  
 Number of rows and material . . . . . 226  
 Fins per inch and material . . . . . 7  
 Width of matrix  
 -temperate . . . . . 1600 mm  
 -tropical . . . . . 1805 mm  
 Height of matrix . . . . . 1644 mm  
 Weight (dry)  
 -temperate . . . . . 780 kg  
 -tropical . . . . . 843 kg  
 Total coolant capacity  
 -temperate . . . . . 123 litres  
 -tropical . . . . . 128 litres  
 Pressure cap setting (min) . . . . . 69 kPa

### Fan

Type . . . . . engine driven  
 Diameter  
 -temperate . . . . . 1400 mm  
 -tropical . . . . . 1530 mm  
 Number of blades . . . . . 12  
 Material . . . . . Aluminium  
 Drive ratio  
 -temperate . . . . . 1:1  
 -tropical . . . . . 1:0,9

## Cooling clearance

### 4012-46TWG2A - Temperate

Maximum additional restriction (duct allowance) to cooling airflow, and resultant min airflow			
Description	°C	Pa	m <sup>3</sup> /sec
Ambient clearance: Inhibited coolant	35	N/A	N/A
Duct allowance	35	250	N/A
Minimum airflow	35	250	22

### 4012-46TWG2A - Tropical

Maximum additional restriction (duct allowance) to cooling airflow, and resultant min airflow			
Description	°C	Pa	m <sup>3</sup> /sec
Ambient clearance: Inhibited coolant	50	N/A	N/A
Duct allowance	50	125	N/A
Minimum airflow	50	125	28

### 4012-46TWG3A - Temperate

Maximum additional restriction (duct allowance) to cooling airflow, and resultant min airflow			
Description	°C	Pa	m <sup>3</sup> /sec
Ambient clearance: Inhibited coolant	35	N/A	N/A
Duct allowance	35	250	N/A
Minimum airflow	35	250	22

### 4012-46TWG3A - Tropical

Maximum additional restriction (duct allowance) to cooling airflow, and resultant min airflow			
Description	°C	Pa	m <sup>3</sup> /sec
Ambient clearance: Inhibited coolant	50	N/A	N/A
Duct allowance	50	125	N/A
Minimum airflow	50	125	28

## Fuel system

Injection system .....	direct injection
Fuel injection pump/Injector type .....	Combined unit injector
Injector pressure .....	23,4 MPa
Fuel lift pump type.....	Gerotor
Delivery flow.....	1020 litres/hr
Heat retained in fuel to tank	
-4012-46TWG2A .....	8,5 kW
-4012-46TWG3A .....	9,0 kW
Fuel inlet temperature to be less than .....	58 °C
Delivery pressure .....	300 kPa
Maximum suction head at pump inlet .....	24,5 kPa
Maximum static pressure head .....	see installation manual for details
Fuel filter spacing.....	10 microns
Governing type.....	electronic
Governing .....	to ISO 8528-5 2005
Torque at the governor output shaft.....	1-631
Tolerance on fuel consumption.....	to ISO 8528-1 1993

## Fuel specification

Recommended fuel to conform to: ..... -BS2869 1998 class A2 or BS EN590

## Fuel consumption

**Note:** All fuel consumption figures are based on assumed fuel density of 0.862.

### 4012-46TWG2A - Temperate

Designation	Fuel consumption calculated on nett rated powers	
	1500 rev/min	
	g/kWh	litres/hr
Standby	212	287
Prime power	211	258
Baseload power	213	206
At 75% of Prime power	214	196
At 50% of Prime power	230	141

### 4012-46TWG3A - Temperate

Designation	Fuel consumption calculated on nett rated powers	
	1500 rev/min	
	g/kWh	litres/hr
Standby	215	315
Prime power	211	281
Baseload power	212	224
At 75% of Prime power	212	212
At 50% of Prime power	224	149

### 4012-46TWG2A - Tropical

Designation	Fuel consumption calculated on nett rated powers	
	1500 rev/min	
	g/kWh	litres/hr
Standby	213	288
Prime power	212	259
Baseload power	214	207
At 75% of Prime power	216	196
At 50% of Prime power	233	143

### 4012-46TWG3A - Tropical

Designation	Fuel consumption calculated on nett rated powers	
	1500 rev/min	
	g/kWh	litres/hr
Standby	217	318
Prime power	212	283
Baseload power	213	225
At 75% of Prime power	213	213
At 50% of Prime power	226	151

## Electrical system

Alternator  
 -type ... insulated return  
 -voltage ... 24 volts  
 -output ... 40 amps  
 Starter  
 -type ... (axial) electric  
 -motor voltage ... 24 volts  
 -motor power ... 16,4 kW  
 Number of teeth on  
 -flywheel ... 156  
 -starter motor ... 12  
 Minimum cranking speed ... 120 rev/min  
 Starter solenoid (24V)  
 -pull in current @ -25 °C max. ... 30 amps  
 -hold in current @ -25 °C max ... 9 amps  
 Engine stop solenoid current ... 1,1 amps

## Engine mounting

Maximum static bending moment at rear face of block ... 1356 Nm  
 Maximum additional load applied to flywheel due to rotating components ... 850 kg

## Centre of gravity

Bare engine (wet) 4012-46TWG2A / 4012-46TWG3A  
 -forward of rear face of cylinder block ... 658 mm  
 -above crankshaft centre line ... 32 mm  
 ElectropaK (wet) - Temperate  
 -forward of rear face of cylinder block ... 960 mm  
 -above crankshaft centre line ... 32 mm  
 ElectropaK (wet) - Tropical  
 -forward of rear face of cylinder block ... 1286 mm  
 -above crankshaft centre line ... 32 mm

## Cold start recommendations

Temperature range	
Down to 0 °C (32 °F)	Oil: ... API CH4 15W40 Starter: ... 2 x 24 volts Battery: ... 4 x 12V 286 Ah Max breakaway current: ... 1600 amps Cranking current: ... 810 amps Aids: ... block heaters Min mean cranking speed: ... 120 rev/min

### Notes:

- The battery capacity is defined by the 20 hour rate
- The oil specification should be for the minimum ambient temperature as the oil will not be warmed by the immersion heater
- Breakaway current is dependant on battery capacity available. Cables should be capable of handling the transient current which may be up to double the steady cranking current.

## Lubrication system

Recommended multigrade oil viscosity (15W40) which adequately meets the specifications of API CH4. For further details refer to the engine OMM.

### Lubricating oil capacity

Total system ... 177 litres  
 Sump maximum ... 157,5 litres  
 Sump minimum ... 115 litres  
 Oil temperature at normal operating conditions ... 95 °C  
 Oil temperature (in rail) - maximum continuous operation .. 105 °C

### Lubricating oil pressure

minimum ... 340 kPa  
 At rated speed ... 400 kPa  
 Oil relief opens ... 400 kPa  
 Oil filter screen spacing ... 20 microns  
 Sump drain plug tapping size ... G1  
 Lubricating oil pump speed ... 1.4 x engine rev/min  
 Lubricating oil pump drive method ... engine driven  
 Shutdown switch - pressure setting (where fitted) 193 kPa (falling)

### Normal operating angles

-front and rear ... 5°  
 -side tilt ... 10°

Oil consumption (prime power)		4012-46TWG2A	4012-46TWG3A
After running-in (typically after 250 hours)	g/kWhr	0,52	0,52
Oil flow rate from oil pump	l/s	6,0	6,0

## Noise levels

The figures for total noise levels are typical for an engine running at the standby power rating in a semi-reverberant environment and measured at a distance of one metre from the periphery of the engine (sound pressure level re:  $-20 \times 10^{-6}$  pa).

Ambient noise level..... 70 dB(A)

## Octave analysis

The following diagrams show maximum noise level.

### Noise data 4012-46TWG3A, 1500 rev/min 1263 kWb with radiator 584/471FC

Position	SPL dBA
1	114.1
2	112.9
3	113.0
4	111.7
5	113.0
6	114.2

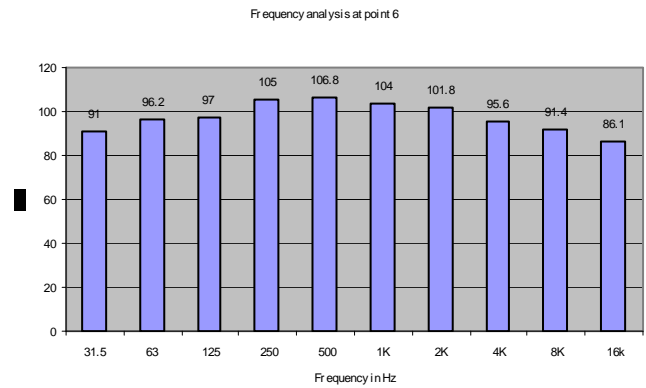
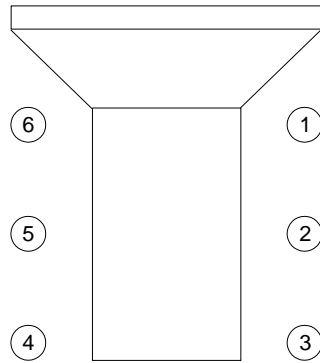

### Noise data 4012-46TWG3A, 1500 rev/min 1263 kWb with radiator 584/485FC

Position	SPL dBA
1	113.5
2	113.2
3	112.0
4	111.7
5	113.1
6	112.8

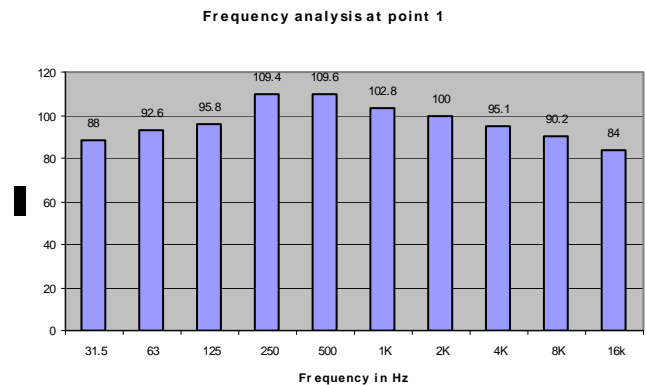
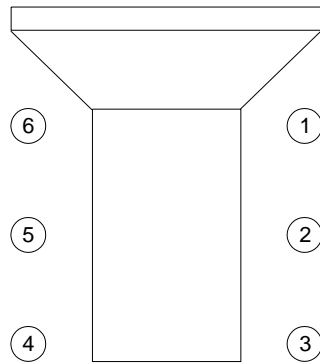

**Note:** The information given on this Technical Data Sheet is for standard ratings only. For ratings other than those shown, please contact Perkins Engines Company Limited.

## Load acceptance (cold)

4012-46TWG2A (prime %)	72
4012-46TWG3A (prime %)	65
Engine block temperature (cold)	45 °C
Ambient temperature	25 °C
Governing mode	Isochronous
Alternator inertia	50 kgm <sup>2</sup>
Under frequency roll off (UFRO) point set to	49 Hz
UFRO rate set to	16 V/Hz
LAM on/off	on

## Notes:

- All test were conducted using an engine installed and serviced to Perkins Engine Company Limited recommendations.
- Applied load is a percentage of the generator electrical output efficiencies as published in the general installation section of this data sheet.



Perkins Engines Company Limited  
Peterborough PE1 5NA United Kingdom  
Telephone +44 (0) 1733 583000  
Fax +44 (0) 1733 582240  
[www.perkins.com](http://www.perkins.com)

All information in the document is substantially correct at the time of printing but may be subsequently altered by the company.

Distributed by