

1106A-70TG1

135.8 kWm (Gross) @ 1500rpm

Electropak

1100

Series

Basic technical data

Number of cylinders	6
Cylinder arrangement	In-line
Cycle	4 stroke
Induction system	Turbocharged
Combustion system	Direct injection diesel
Compression ratio	18.2:1
Bore	105 mm
Stroke	135 mm
Cubic capacity	7.01 litres
Direction of rotation	Anticlockwise when viewed from flywheel
Firing order	1, 5, 3, 6, 2, 4
Estimated total weight (dry)	725 kg
Estimated total weight (wet)	748 kg

Overall dimensions, Electropak

Height	1042 mm
Length (air cleaner fitted)	1509 mm
Width	760 mm

Moments of inertia

Engine rotational components	0.27 kgm ²
Flywheel	1.20 kgm ²

Centre of gravity, Electropak

Forward from rear of block (wet)	426 mm
Above crankshaft centre line (wet)	159 mm
Offset to RHS of crankshaft centre line (wet)	-14 mm

Performance

Speed variation at constant load	± 0.75%
Cyclic irregularity at standby power	0.028
All ratings within	± 5%

Note: All data based on operation to ISO 3046-1:2002 standard reference conditions.

Sound level

Average sound pressure level for prime power @ 1 m TBA dB(A)

Test conditions

Air temperature	25°C
Barometric pressure	100 kPa
Relative humidity	31.5%
Air inlet restriction at maximum power	3 kPa (maximum)
Exhaust back pressure at maximum power	6 kPa (maximum)
Fuel temperature	40°C

Note: If the engine is to operate in ambient conditions other than those of the test conditions, suitable adjustments must be made for these changes. For full details, contact Perkins Technical Service Department.

General installation

General installation	Units	Prime	Standby
Gross engine power	kW	122.7	135.8
Gross BMEP	kPa	1400.3	1549.8
Mean piston speed	metres/s	6.8	
ElectropaK nett engine power	kW	118.3	131.4
Engine coolant flow (against 35 kPa restriction)	litres/min	142.0	
Combustion air flow (at STP)	m ³ /min	7.64	8.09
Exhaust gas flow (maximum)	m ³ /min	20.75	22.66
Exhaust gas temperature (maximum) in manifold (after turbocharger)	°C	576.0	
Nett engine thermal efficiency	%	39.0	39.0
Typical generator set electrical output (0.8pf 25°C)	kWe	108.0	120.0
	kVA	135.0	150.0
Regenerative power (estimated)	kW	6.1	
Assumed alternator efficiency	%	91.3	

Rating definitions

Prime power

Unlimited hours usage, with an average load factor of 80 percent over each 24 hour period. A 10 percent overload is available for 1 hour in every 12 hours operation.

Standby power

Limited to 500 hours annual usage, with an average load factor of 80 percent of the published standby power rating over each 24 hour period. Up to 300 hours of annual usage may be run continuously. No overload is permitted on standby power.

Energy balance

Designation	Units	Prime	Standby
Heat in fuel	kW	300.9	336.2
Power to cooling fan	kW	4.4	
Power to coolant and lubricating oil	kW	74.9	82.0
Power to exhaust	kW	89.8	102.0
Power to radiation	kW	13.5	16.4

Note: Not to be used for CHP design purposes (indicative figures only). Consult Perkins Engines Company Limited. Assumes complete combustion.

Cooling system

Radiator

Overall weight (wet)	35kg
Face area	464025 mm ²
Number of rows and materials	2 rows, Aluminium
Matrix density and material	12.7 fins per inch, Aluminium
Width of matrix	672.5 mm
Height of matrix	690 mm
Pressure cap setting (minimum)	110 kPa

Fan

Diameter	558.8 mm
Drive ratio	1.43:1
Number of blades	7
Material	Nylon
Type	Pusher
Air flow, 1500 rpm @ 200 Pa air side restriction	182 m ³ /min
Power, 1500 rpm @ 200 Pa air side restriction	5.7 kW

Coolant

Total system capacity	21 litres
System drawdown capacity	10%
Engine capacity	9.5 litres
Maximum top tank temperature	110°C
Temperature rise across engine (Maximum rating dependent)	6°C - 12°C
Maximum permissible external system resistance	35 kPa
Thermostat operation range	82°C to 93°C
Shutdown switch setting	118°C
Coolant pump method of drive	Gear
Recommended coolant immersion heater rating (minimum)	0.75 kW
Recommended coolant	BS6580 - 1992, ASTM D3306 and ELC coolants to 1E1966

Duct allowance

Maximum additional restriction (duct allowance to cooling airflow and resultant minimum air flow) - standby power

Description	rpm	kPa	m ³ /min
Duct allowance with inhibited coolant at 50°C			
Minimum air flow	1500	0.120	252
Duct allowance with inhibited coolant at 46°C			
Minimum air flow	1500	0.200	234

Electrical system

Alternator	8SI
Alternator voltage	12 volts
Alternator output	65 amps
Starter	AZF
Starter motor voltage	12 volts
Starter motor power	4.2 kW
Number of teeth on the flywheel	126
Pull-in and hold-in current of starter motor solenoid @ 25°C maximum ⁽¹⁾	12 volts 68 amps
Hold-in current of starter motor solenoid @ 25°C maximum ⁽¹⁾	12 volts 20 amps
Engine stop method	Solenoid

¹ All leads to rated at 10 amps minimum

Cold start recommendations

Minimum required cranking speed over TDC

	5 to -10°C	-10 to -20°C	-20 to -25°C
Oil	15W40	10W40	5W40
Starter	AZF		
Battery	2x 1200 CCA		
Cranking current	960		
Aids	None	Glow plugs	
Minimum mean cranking speed	130 rpm	100 rpm	100 rpm

Note: Battery capacity is defined by the 20 hour rate.

Note: If a change to a low viscosity oil is made, the cranking torque necessary at low ambient temperatures is much reduced. The starting equipment has been selected to take advantage of this. It is important to change to the appropriate multigrade oil in anticipation of operating in low ambient temperatures.

Exhaust system

Maximum back pressure - 1500 rpm	6.0 kPa
Exhaust outlet, internal diameter	72 mm

Fuel system

Injection components

Injector Mechanical
 Fuel pump..... DPG

Fuel priming

Priming pump type Manual
 Maximum priming time..... 90 seconds

Fuel feed

Maximum fuel flow 3 litres/min
 Maximum suction head at engine fuel pump inlet..... 50 kPa
 Maximum static pressure head 50 kPa
 Maximum fuel temperature at engine fuel pump inlet 85°C
 Tolerance on fuel consumption ± 5%

Fuel specification

Fuel standard..... Various (contact Perkins Technical Department)

Fuel consumption

Load	Type of operation and application	
	g/kWh	litres/hr
110% prime power	205.9	33.8
Prime power	203	30.3
75% prime power	204.5	22.7
50% prime power	213.9	15.9
25% prime power	242.7	9.0

Induction system

Maximum air intake restriction

Clean filter 3 kPa
 Dirty filter..... 5 kPa
 Air filter type..... Paper element

Lubrication system

Maximum total system oil capacity 18.0 litres
 Minimum oil capacity in sump 12.5 litres
 Maximum oil capacity in sump 16.1 litres
 Maximum engine operating angles -
 Front up, front down, right side, left side..... 25°
 Sump drain plug tapping size..... 3/4 - 16 UNF
 Shutdown switch setting (where fitted)

Lubricating oil

Relief valve opening pressure 460 kPa
 Pressure at maximum speed 520 kPa
 Maximum continuous oil temperature (in rail)..... 125°C
 Oil consumption at full load (% of fuel) < 0.1

Recommended SAE viscosity

A multigrade oil must be used which conforms to API CH4 or CI4
 ACEA E5 must be used, see illustration below:

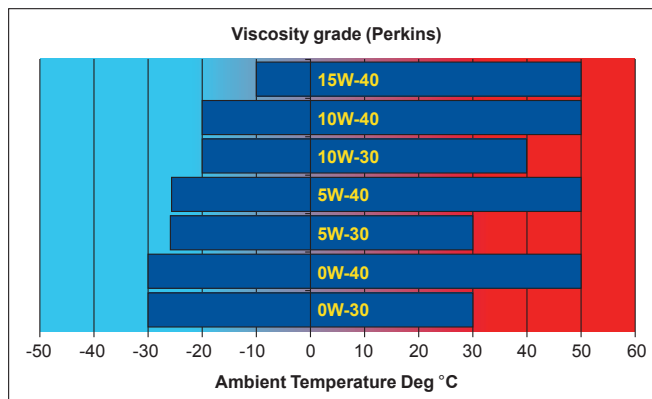

Mountings

Maximum static bending moment at rear face of block..... 1130 Nm
 Maximum permissible overhung load
 on the flywheel..... Calculated on request
 Maximum bending moment at rear of flywheel housing..... ± 3000 in Shock Nm

Load acceptance

The data below complies with the requirements of classification 3 and 4
 of ISO 8528-12 and G2 operating limits stated in ISO 8528-5.

Initial load application: When engine reaches rated speed (15
 seconds maximum after engine starts to crank).

Description	Units	Cold Condition
% of prime power	%	90
Load	kWe	97.2
Transient frequency deviation	%	< 10
Frequency recovery time	Seconds	1.38

Noise data

Noise levels

Noise level dB(A)		
Position	Prime power	Standby
1	96.4	96.5
2	93.8	93.8
3	94.6	94.5
4	97.2	97.1
5	98.6	98.3
6	95.4	95.1

Noise reference level 65 dB(A)

$\frac{1}{3}$ octave analysis: TBC

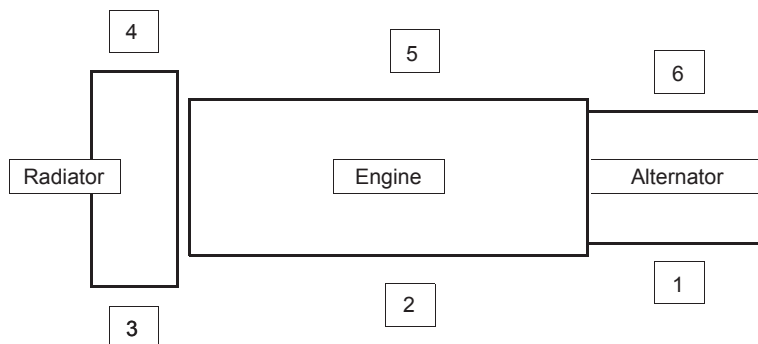

1106A-70TG1 - Left side view

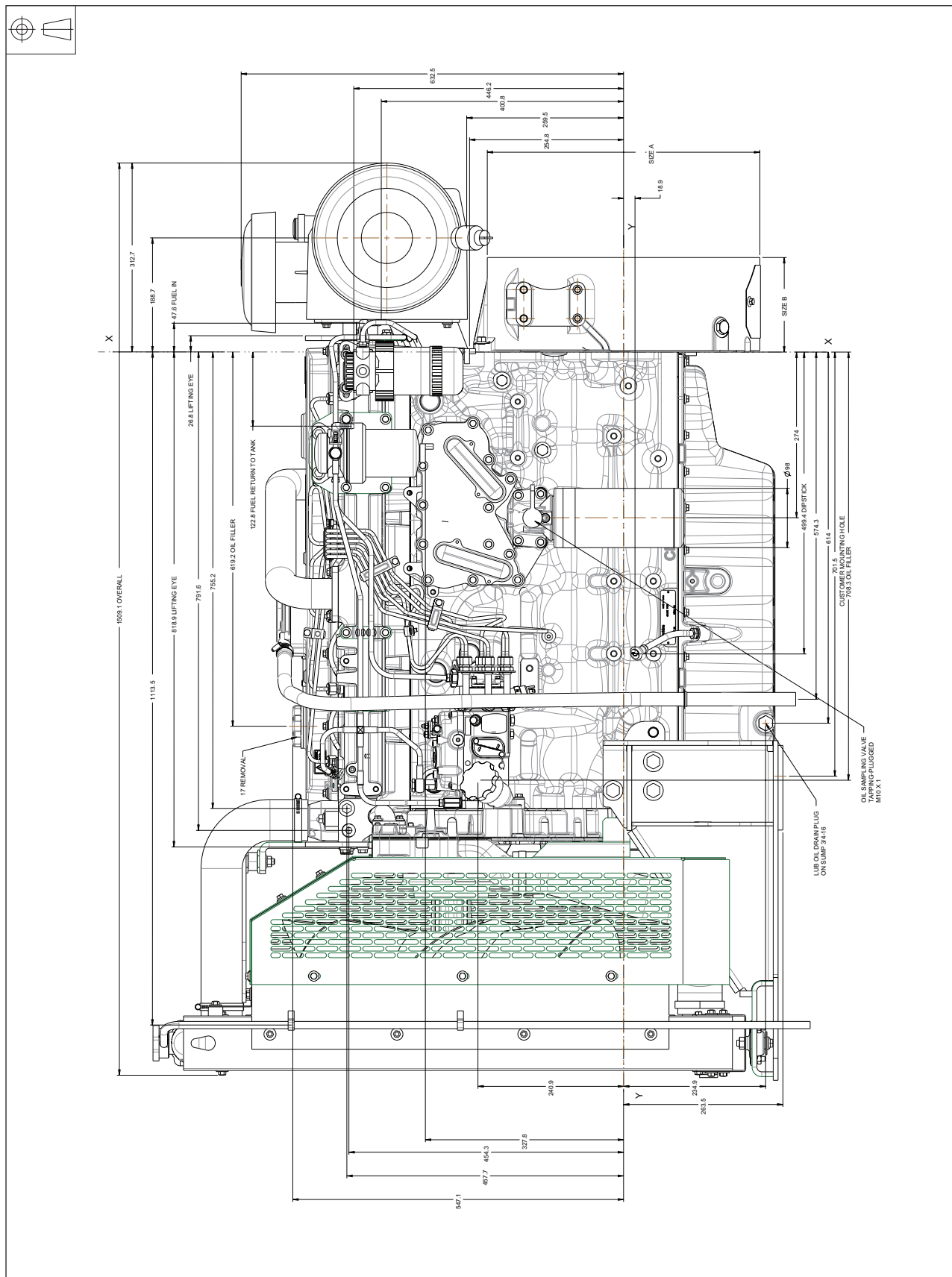

1106A-70TG1 - Front view

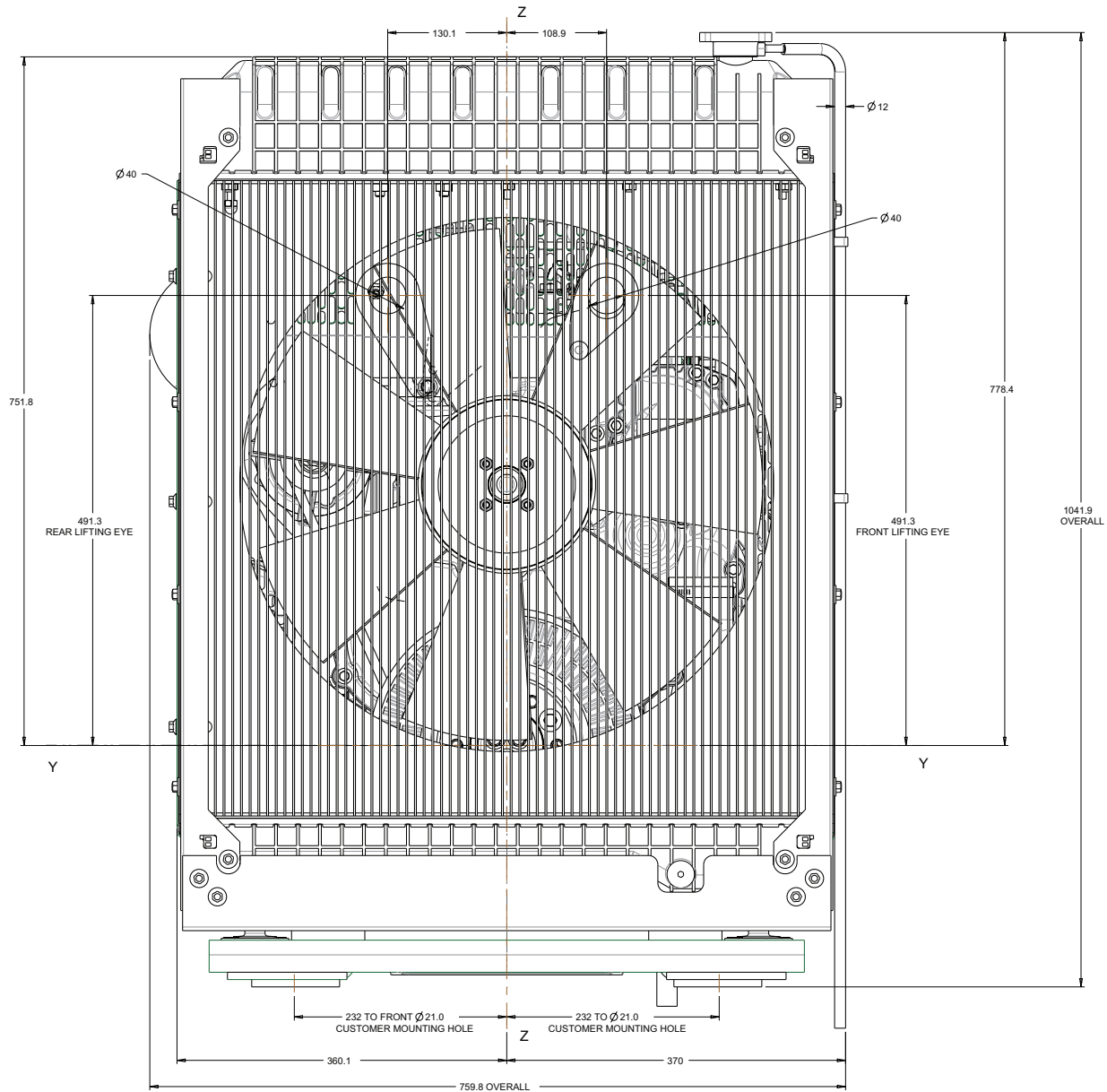

1106A-70TG1 - Right side view

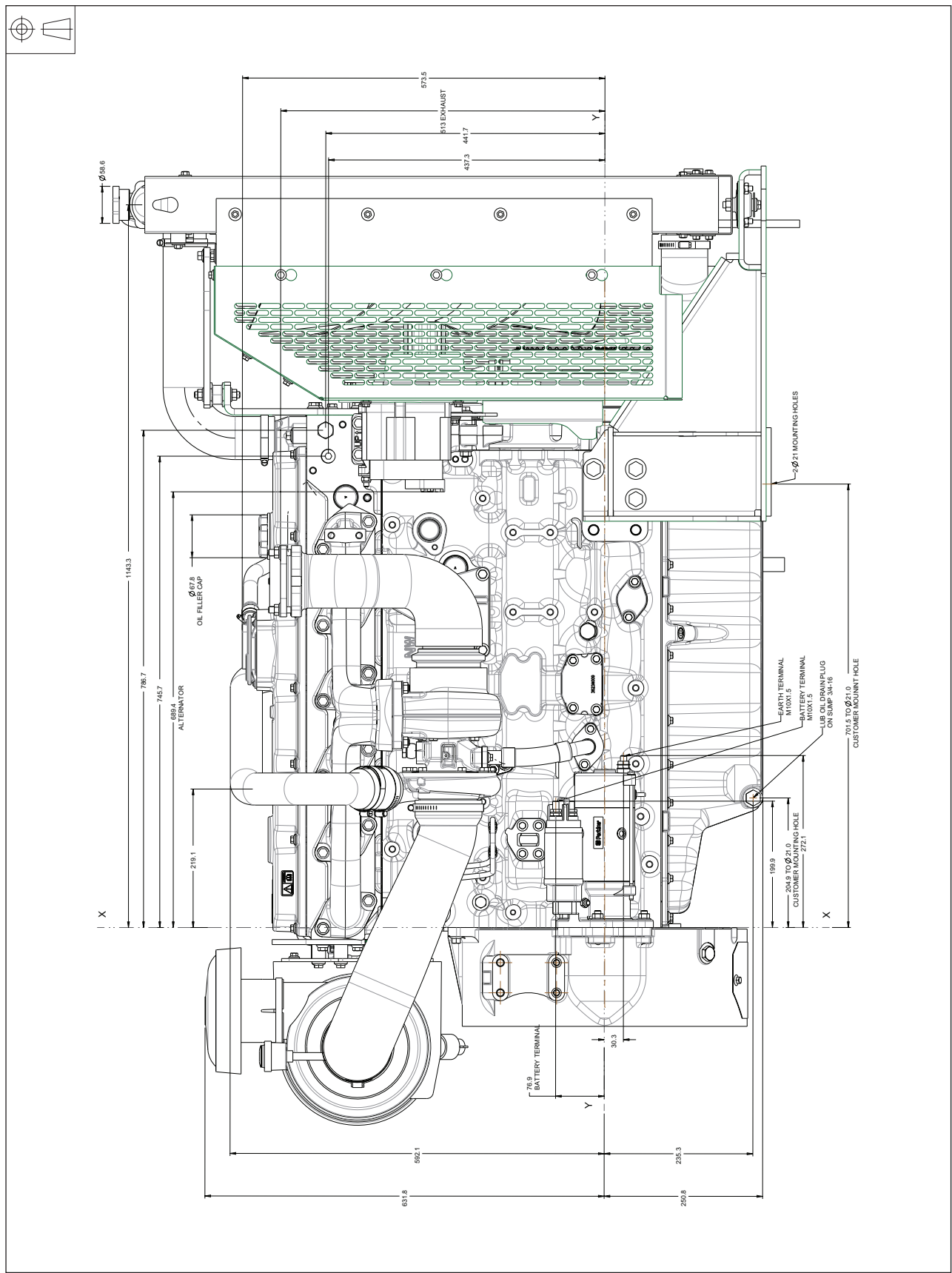

1106A-70TG1 - Rear view

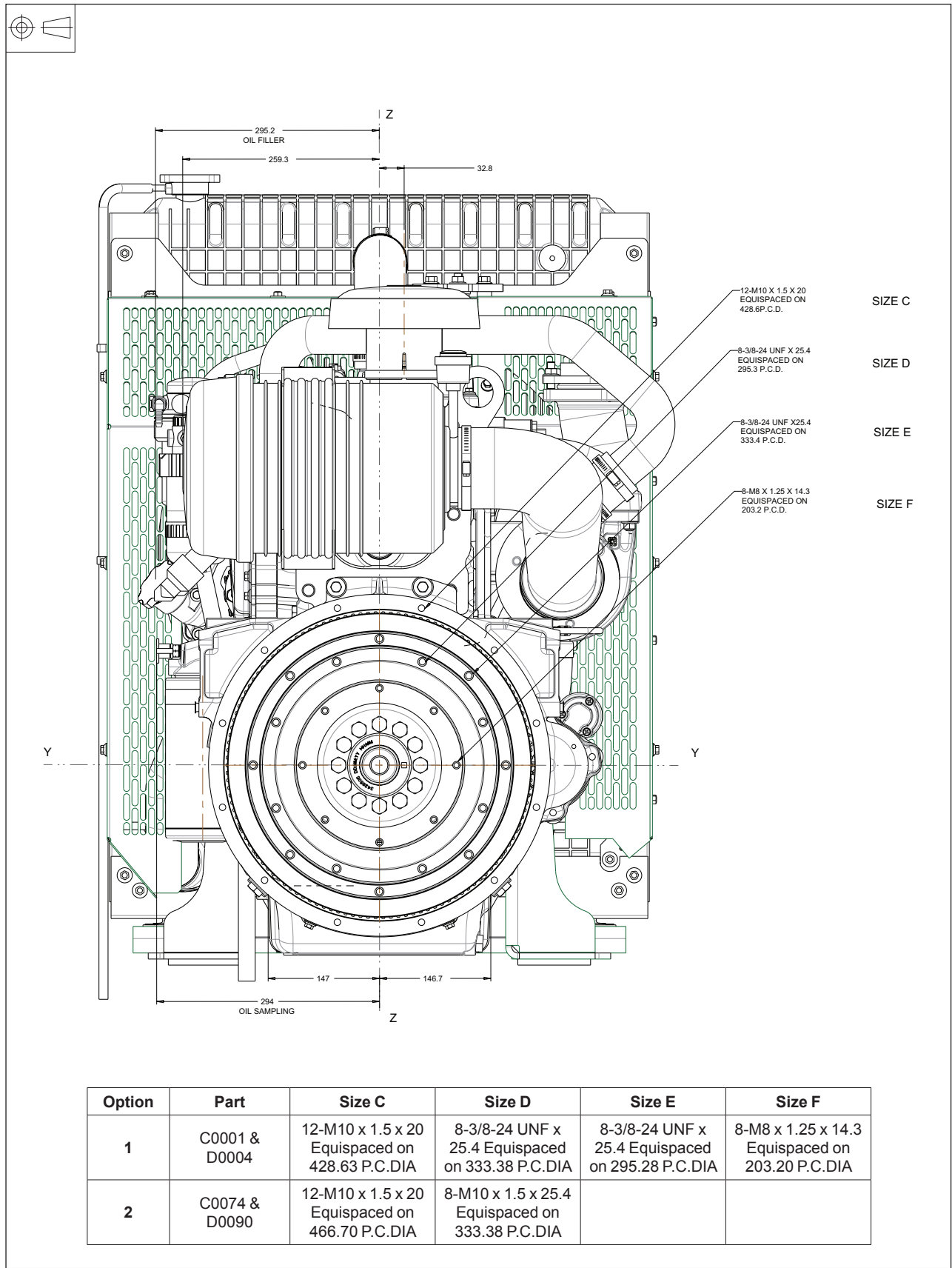

1106A-70TG1 - Plan view

