

1100 Series 1104D-E44TAG2 Diesel Engine – ElectropaK

92.1 kWm (123.5 hp) net prime power @ 1500 rpm
 101.6 kWm (136 hp) net standby power @ 1500 rpm

The Perkins® 1104D-E44TAG ElectropaKs are the latest addition to 1100 Series Electric Power line-up. Offering improved power density from a compact package, these ElectropaK's build on Perkins reputation within the power generation industry.

These ultra clean engines are assembled on a new high technology production line. Frequent computerised checks during the production process ensure high build quality is maintained throughout.

Hitting the key power nodes required by the market, the 1104D ElectropaK product line-up consists of three models offering a power solution for both prime and standby applications, in 50 Hz territories.

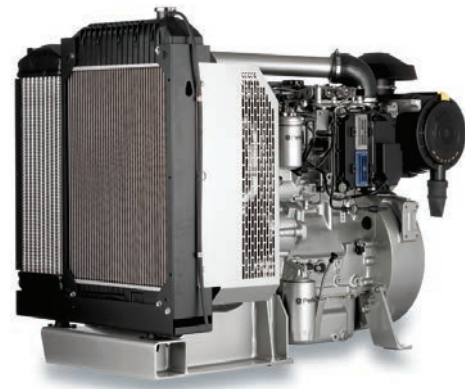

Emissions

Certified against the requirements of EU Stage IIIA legislation for non-road mobile machinery, powered by constant speed engines (EU 97/68/EC Stage IIIA).

Specification		
Number of cylinders	4 in-line	
Bore and stroke	105 x 127 mm	4.1 x 5.0 in
Displacement	4.4 litres	269 in ³
Aspiration	Turbocharged air-to-air chargecooled	
Cycle	4 stroke	
Combustion system	Direct injection	
Compression ratio	16.2:1	
Rotation	Anti-clockwise, viewed on flywheel	
Total lubricating capacity	8 litres	2.1 US gal
Cooling system	Water-cooled	
Total coolant capacity	17 litres	4.5 US gal

www.perkins.com

Photographs are for illustrative purposes only and may not reflect final specification.
 All information in this document is substantially correct at time of printing and may be altered subsequently.
 Final weight and dimensions will depend on completed specification.

Publication No. PN1894A/04/15 Produced in England ©2015 Perkins Engines Company Limited

 **Perkins®**

THE HEART OF EVERY GREAT MACHINE

1100 Series 1104D-E44TAG2 Diesel Engine – ElectropaK

92.1 kWm (123.5 hp) net prime power @ 1500 rpm

101.6 kWm (136 hp) net standby power @ 1500 rpm

Features and benefits

Power to meet your needs

- Hitting the key power nodes required by the market, the 1104D-E44TAG2 ElectropaK has been developed to provide a clean and cost effective power solution

State of the art design

- The 1104D utilises the latest common-rail fuel system technologies with a closely optimised air-management system, which is overseen by the latest generation of electronic engine control. This allows the 1104D range to deliver high power density and excellent fuel economy with low exhaust emissions and minimum heat rejection

Worldwide power solution

- The 1104D has been designed to be worldwide fuel tolerant, and 5% biofuel (RME) options are available to meet local market needs

Lower operating costs

- The 1104D maintains Tier 2 fuel economy, allowing customers to keep existing fuel tanks
- Service intervals are 500 hours standard
- **Warranties and Service Contracts**

We provide one-year warranties for constant speed engines and two-year warranties for variable speed models, as standard. These are supported by multilevel Extended Service Contracts that can be bought additionally
Discover more: www.perkins.esc

- Low usage warranty package is also available

Product support

- Perkins actively pursues product support excellence by ensuring our distribution network invest in their territory – strengthening relationships and providing more value to you, our customer
- Through an experienced global network of distributors and dealers, fully trained engine experts deliver total service support around the clock, 365 days a year. They have a comprehensive suite of web based tools at their fingertips covering technical information, parts identification and ordering systems, all dedicated to maximising the productivity of your engine
- Throughout the entire life of a Perkins engine, we provide access to genuine OE specification parts and service. We give 100% reassurance that you receive the very best in terms of quality for lowest possible cost .. wherever your Perkins powered machine is operating in the world
- To find your local distributor: www.perkins.com/distributor

www.perkins.com

Photographs are for illustrative purposes only and may not reflect final specification.
All information in this document is substantially correct at time of printing and may be altered subsequently.
Final weight and dimensions will depend on completed specification.

Publication No. PN1894A/04/15 Produced in England ©2015 Perkins Engines Company Limited

 **Perkins**[®]

THE HEART OF EVERY GREAT MACHINE

1100 Series 1104D-E44TAG2 Diesel Engine – Electropak

92.1 kWm (123.5 hp) net prime power @ 1500 rpm
101.6 kWm (136 hp) net standby power @ 1500 rpm

Technical information

Air inlet

- Mounted air filter and turbocharger

Cooling system

- 22 inch belt-driven pusher fan and guards
- Radiator (incorporating air-to-air charge cooler)
- Water pump

Electric system

- 12 volt starter motor
- 12 volt, 65 amp alternator with DC output

Flywheel and housing

- High inertia flywheel to SAE J620 Size 10/11
- SAE3 flywheel housing

Fuel system

- Electronic governing (conforms to Class G3 ISO 8528-5)
- Fuel filter

Literature

- Users Handbook

Lubrication system

- Wet cast iron sump with filler and dipstick
- Oil filter

Start aids

- Glow plugs

www.perkins.com

Photographs are for illustrative purposes only and may not reflect final specification.
All information in this document is substantially correct at time of printing and may be altered subsequently.
Final weight and dimensions will depend on completed specification.

Publication No. PN1894A/04/15 Produced in England ©2015 Perkins Engines Company Limited

 **Perkins**[®]

THE HEART OF EVERY GREAT MACHINE

1100 Series 1104D-E44TAG2 Diesel Engine – Electropak

92.1 kWm (123.5 hp) net prime power @ 1500 rpm
101.6 kWm (136 hp) net standby power @ 1500 rpm

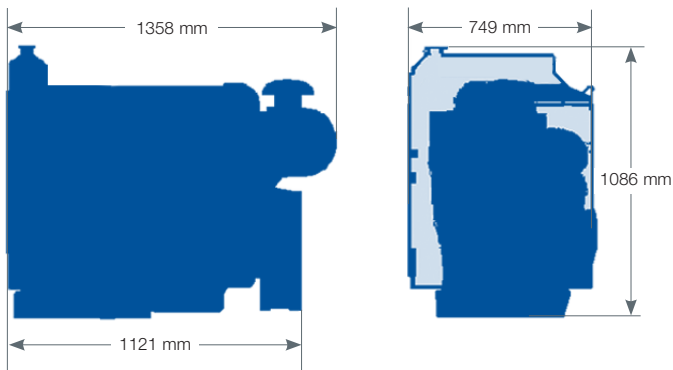

Engine package weights and dimensions		
Length	1358 mm	53.4 in
Width	749 mm	29.5 in
Height	1086 mm	42.7 in
Weight (dry)	465 kg	1025 lb

www.perkins.com

Photographs are for illustrative purposes only and may not reflect final specification.
All information in this document is substantially correct at time of printing and may be altered subsequently.
Final weight and dimensions will depend on completed specification.

Publication No. PN1894A/04/15 Produced in England ©2015 Perkins Engines Company Limited

 **Perkins**[®]

THE HEART OF EVERY GREAT MACHINE

1100 Series 1104D-E44TAG2 Diesel Engine – ElectropaK

92.1 kWm (123.5 hp) net prime power @ 1500 rpm

101.6 kWm (136 hp) net standby power @ 1500 rpm

Speed rpm	Type of operation	Typical generator output (Net)		Engine power			
				Gross		Net	
		kVA	kWe	kWm	hp	kWm	hp
1500	Prime power	101.3	81	95.5	128	92.1	123.5
	Standby (maximum)	111.7	89.4	105	141	101.6	136

The above ratings represent the engine performance capabilities to conditions specified in ISO 8528/5. Derating may be required for conditions outside the test conditions; consult Perkins Engines Company Limited.

Generator powers are typical and are based on typical alternator efficiencies and a power factor. **Fuel specification:** Consult Perkins Engines Company Limited (various fuel specifications are available). **Lubricating oil:** multi-grade oil conforming to API-CH4/CJ4 must be used.

Rating definitions

Prime power: Power available at variable load in lieu of a main power network. Overload of 10% is permitted for 1 hour in every 12 hours' operation.

Standby (maximum): Power available at variable load in the event of a main power network failure. No overload is permitted.

Percent of prime power	Fuel consumption at 1500 rpm l/hr
110%	26.5
100%	24.5
75%	19.8
50%	13.2

www.perkins.com

Photographs are for illustrative purposes only and may not reflect final specification. All information in this document is substantially correct at time of printing and may be altered subsequently. Final weight and dimensions will depend on completed specification.

Publication No. PN1894A/04/15 Produced in England ©2015 Perkins Engines Company Limited



THE HEART OF EVERY GREAT MACHINE